

GeoMax Zoom 20/Zoom 30 Series



GE  **MAX**
Part of Hexagon Group

User Manual
Version 1.0

Introduction

Purchase

Congratulations on the purchase of a GeoMax Zoom instrument.



This manual contains important safety directions as well as instructions for setting up the product and operating it. Refer to "13 Safety Directions" for further information.



Read carefully through the User Manual before you switch on the product.

Product identification





The type and serial number of your product are indicated on the type plate. Enter the type and serial number in your manual and always refer to this information when you need to contact your agency or GeoMax authorised service workshop.

Type: _____

Serial No.: _____

Symbols

The symbols used in this manual have the following meanings:

Type	Description
 Danger	Indicates an imminently hazardous situation which, if not avoided, will result in death or serious injury.
 Warning	Indicates a potentially hazardous situation or an unintended use which, if not avoided, could result in death or serious injury.
 Caution	Indicates a potentially hazardous situation or an unintended use which, if not avoided, may result in minor or moderate injury and/or appreciable material, financial and environmental damage.
	Important paragraphs which must be adhered to in practice as they enable the product to be used in a technically correct and efficient manner.

Trademarks

- Windows is a registered trademark of Microsoft Corporation.
 - Bluetooth is a registered trademark of Bluetooth SIG, Inc.
- All other trademarks are the property of their respective owners.

Validity of this manual

	Description
General	This manual applies to Zoom 20 and Zoom 30 instruments. Where there are differences between the instruments they are clearly described.
Telescope	<ul style="list-style-type: none"> • Measuring with IR modes: When measuring distances to a reflector with Electronic Distance Measurement (EDM) mode "IR", the telescope uses a wide visible red laser beam, which emerges coaxially from the telescope's objective. • Measuring with RL modes: Instruments that are equipped with a reflectorless EDM additionally offer the EDM mode "Reflectorless (RL)". When measuring distances with this EDM mode, the telescope uses a narrow visible red laser beam, which emerges coaxially from the telescope's objective.

 **Warning**

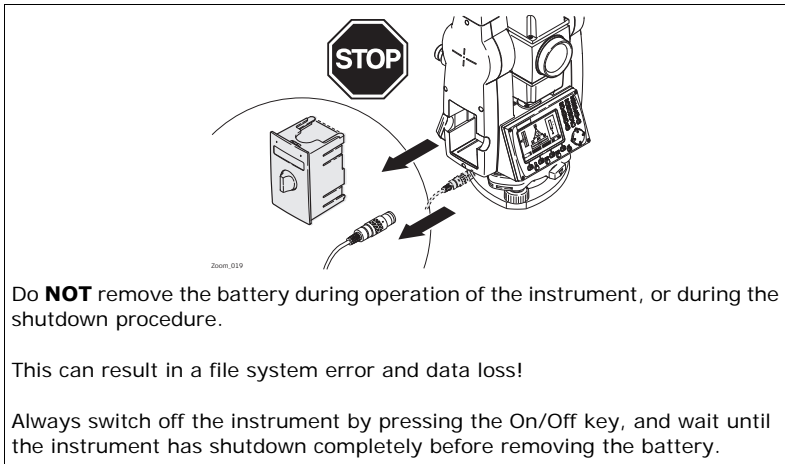

Do **NOT** remove the battery during operation of the instrument, or during the shutdown procedure.

This can result in a file system error and data loss!

Always switch off the instrument by pressing the On/Off key, and wait until the instrument has shutdown completely before removing the battery.

Table of Contents

In this manual	Chapter	Page
	1 Description of the System	13
	1.1 System Components	13
	1.2 Container Contents	15
	1.3 Instrument Components	17
	2 User Interface	19
	2.1 Keyboard	19
	2.2 Screen	21
	2.3 Status Icons	22
	2.4 Softkeys	24
	2.5 Operating Principles	26
	2.6 Pointsearch	28
	3 Operation	30
	3.1 Instrument Setup	30
	3.2 Working with the Battery	36
	3.3 Data Storage	39
	3.4 Main Menu	40

3.5	Survey Application	42
3.6	Distance Measurements - Guidelines for Correct Results	44
4	Settings	47
4.1	General Settings	47
4.2	EDM Settings	57
4.3	Communication Settings	61
5	Tools	64
5.1	Calibration	64
5.2	Auto Start Routine	65
5.3	System Information	67
5.4	Loading Software	69
6	Functions	71
6.1	Overview	71
6.2	Distance Offset	73
6.3	Z-Coordinate	76
6.4	2 Dist. Offset	78
6.5	Control Distance	81
6.6	EDM Continuous	83
7	Coding	84

8	Applications - Getting Started	87
<hr/>		
8.1	Overview	87
8.2	Starting an Application	88
8.3	Selecting the Job	90
8.4	Selecting the Station	92
8.5	Selecting the Orientation	94
8.5.1	Overview	94
8.5.2	Manual Orientation	95
8.5.3	Orientation with Coordinates	97
9	Applications	101
<hr/>		
9.1	Common Fields	101
9.2	Survey	102
9.3	Reference Element - Reference Line	104
9.3.1	Overview	104
9.3.2	Defining the Base Line	105
9.3.3	Defining the Reference Line	106
9.3.4	Subapplication Measure Line & Offset	109
9.3.5	Subapplication Setout	111
9.4	Reference Element - Reference Arc	116
9.4.1	Overview	116
9.4.2	Defining the Reference Arc	117

9.4.3	Subapplication Measure Line & Offset	119
9.4.4	Subapplication Setout	120
9.5	COGO	126
9.5.1	Starting COGO	126
9.5.2	Inverse and Traverse	127
9.5.3	Intersections	129
9.5.4	Offsets	132
9.5.5	Extension	134
9.6	Missing Line Measurement	135
9.7	Resection	138
9.7.1	Starting Resection	138
9.7.2	Measuring Information	141
9.7.3	Computation Procedure	142
9.7.4	Resection Results	143
9.8	Set Out	146
9.9	Area & Volume	151
9.10	Remote Elevation	155
9.11	Construction	157
9.11.1	Starting Construction	157
9.11.2	Layout	158
9.11.3	As Built Check	160

10 Data Management	162
<hr/>	
10.1 Data Management	162
10.2 Exporting Data	165
10.3 Importing Data	169
10.4 Working with a USB Memory Stick	172
10.5 Working with Bluetooth	173
10.6 Working with GeoMax Geo Office and GGO Tools	175
11 Calibration	176
<hr/>	
11.1 Overview	176
11.2 Preparation	178
11.3 Calibrating Line-of-Sight and Vertical Index Error	179
11.4 Calibrating the Circular Level of the Instrument and Tribrach	184
11.5 Inspecting the Laser Plummet of the Instrument	186
11.6 Servicing the Tripod	188
12 Care and Transport	189
<hr/>	
12.1 Transport	189
12.2 Storage	190
12.3 Cleaning and Drying	191

13 Safety Directions	193
13.1 General	193
13.2 Intended Use	194
13.3 Limits of Use	196
13.4 Responsibilities	197
13.5 Hazards of Use	199
13.6 Laser Classification	205
13.6.1 General	205
13.6.2 Distancer, Measurements with Reflectors	206
13.6.3 Distancer, Measurements without Reflectors (Reflectorless mode)	208
13.6.4 Laser Plummet	213
13.7 Electromagnetic Compatibility EMC	216
13.8 FCC Statement, Applicable in U.S.	219
14 Technical Data	222
14.1 Angle Measurement	222
14.2 Distance Measurement with Reflectors	223
14.3 Distancer, Measurements without Reflectors (Reflectorless mode)	225
14.4 Distance Measurement Reflector (Long Range)	228
14.5 Conformity to National Regulations	230

14.5.1	Zoom 20	230
14.5.2	Zoom 30	231
14.6	General Technical Data of the Instrument	232
14.7	Scale Correction	238
14.8	Reduction Formulas	241
15	International Limited Warranty	244
16	Glossary	246
Appendix A	Menu Tree	250
Appendix B	Directory Structure	253
Index		254

1 Description of the System

1.1 System Components

Main Components

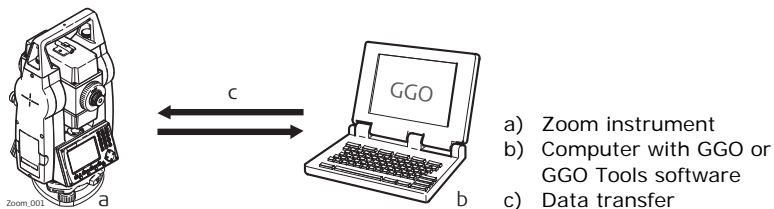

Component	Description
Zoom instrument	An instrument for measuring, calculating and capturing data. Ideally suited for tasks from simple surveys to complex applications. The various lines have a range of accuracy classes and support different features. All lines can be connected with GGO or GGO Tools to view, exchange and manage data.

Component	Description
Firmware	The firmware package installed on the instrument. Consists of a standard base operating system with optional additional features.
GGO or GGO Tools software	An office software consisting of a suite of standard and extended programs for the viewing, exchanging, managing and post processing of data.
Data transfer	Data can be always transferred between a Zoom instrument and a computer via a data transfer cable. For Zoom 30 instruments data can also be transferred via USB memory stick or Bluetooth.

1.2 Container Contents

Container contents part 1 of 2

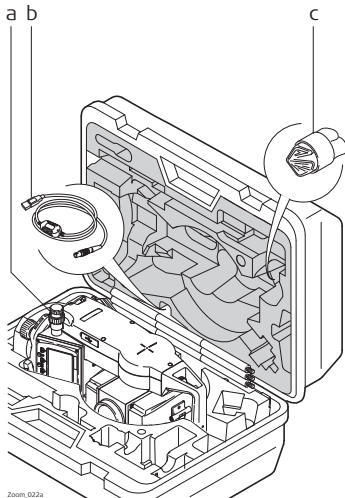

- a) Instrument with supplied tribrach
- b) ZDC100 data cable (USB-RS232)*
- c) Protective cover

* Optional

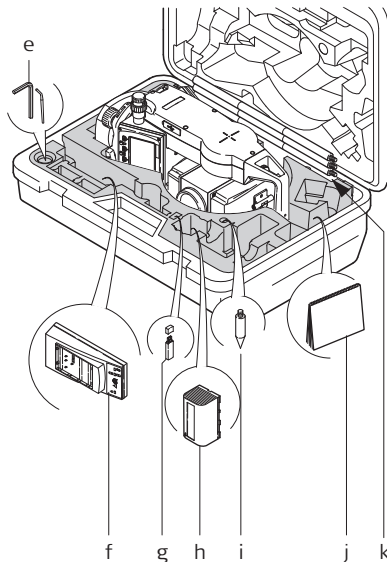
**Container
contents part 2 of
2**

- d) Adjustment tools
- e) ZBA200 battery charger*
- f) USB memory stick - for Zoom 30 instruments*
- g) ZBA400 battery*
- h) Tip for mini prism pole*
- i) User manual
- j) GLS115 mini prism pole*

* Optional

1.3 Instrument Components

Instrument components part 1 of 2

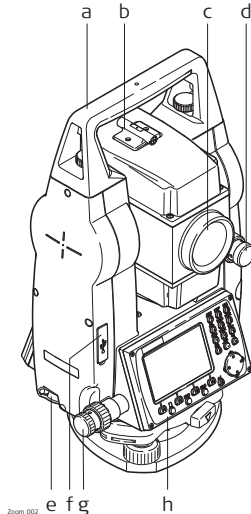

- a) Detachable carrying handle with mounting screw
- b) Optical sight
- c) Objective with integrated Electronic Distance Measurement (EDM). Exit for EDM laser beam
- d) Vertical drive
- e) Serial interface RS232/USB
- f) USB host port
- g) Horizontal drive
- h) Second keyboard*

* Optional

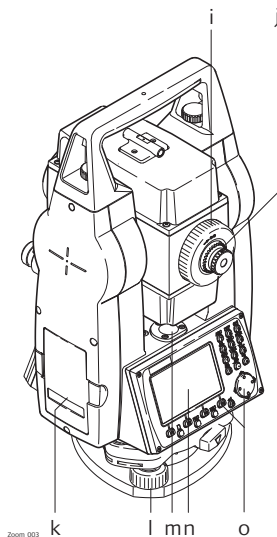
**Instrument
components part
2 of 2**

- i) Focusing telescope image
- j) Eyepiece; focusing graticule
- k) Battery cover
- l) Foot screw
- m) Circular level
- n) Display
- o) Keyboard

2 User Interface

2.1 Keyboard

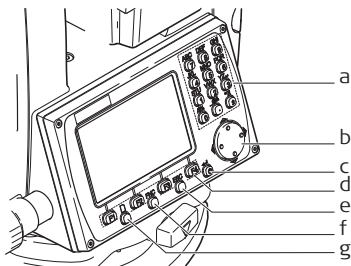

Alphanumeric keyboard







Zoom_009

- a) Alphanumeric keypad
- b) Navigation key
- c) **ENTER** key
- d) Function keys **F1** to **F4**
- e) **ESC** key
- f) **FNC** key
- g) **PAGE** key

Keys

Key	Description
	Page key. Displays the next screen when several screens are available.
	FNC key. Quick-access to measurement supporting functions.

Key	Description
	Navigation key. Controls the focus bar within the screen and the entry bar within a field.
	ENTER key. Confirms an entry and continues to the next field.
	ESC key. Quits a screen or edit mode without saving changes. Returns to next higher level.
	Function keys that are assigned the variable functions displayed at the bottom of the screen.
	Alphanumeric keypad for entry of text and numerical values.

2.2 Screen

Screen

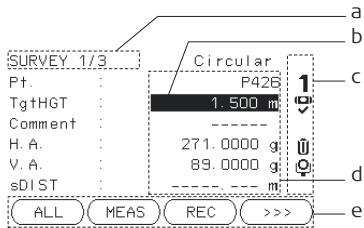

- a) Title of screen
- b) Focus in screen. Active field
- c) Status icons
- d) Fields
- e) Softkeys









All shown screens are examples. It is possible that local firmware versions are different to the basic version.







2.3 Status Icons

Description

The icons provide status information related to basic instrument functions. Depending on the firmware version, different icons are displayed.

Icons

Icon	Description
	The battery symbol indicates the level of the remaining battery capacity, 75% full shown in the example.
	Compensator is on.
	Compensator is off.
	IR EDM mode for measuring to prisms and reflective targets.
	RL EDM mode for measuring to all targets.
	Offset is active.
NUM	Keypad is set to numeric mode.
a	Keypad is set to alphanumeric mode.

Icon	Description
	Indicates that horizontal angle is set to left side angle measurement (anticlockwise).
	A double arrow indicates a field has a selectable list.
	Up and down arrows indicate that several screens are available, which are accessed using  .
1	Indicates telescope position is face I.
2	Indicates telescope position is face II.
	Bluetooth is connected. If there is a cross beside the icon, the Bluetooth communication port is selected, but the status is inactive.
	USB communication port is selected.

2.4 Softkeys

Description

Softkeys are selected using the relevant **F1** to **F4** function key. This chapter describes the functionality of the common softkeys used by the system. The more specialised softkeys are described where they appear in the application chapters.

Common softkey functions

Key	Description
ALPHA	To change the keypad operation to alphanumerical.
NUM	To change the keypad operation to numerical.
ALL	To start distance and angle measurements and save the measured values.
BACK	To return to the last active screen.
COORD	To open the manual coordinate entry screen.
EDM	To view and change EDM settings. Refer to "4.2 EDM Settings".
EXIT	To exit the screen or application.
MEAS	To start distance and angle measurements without saving the measured values.

Key	Description
OK	If entry screen: Confirms measured or entered values and continues the process. If message screen: Confirms message and continues with selected action or returns to the previous screen to reselect an option.
IR/RL	To toggle between IR and RL EDM modes.
DISPL.	To display the list of available points.
REC	To save the displayed values.
DEFLT	To reset all editable fields to their default values.
SEARCH	To search for an entered point.
VIEW	To display the coordinate and job details of the selected point.
> > >	To display the next softkey level.

2.5 Operating Principles

Turn instrument on/off

Use the On/Off key.

Alphanumeric keypad

The alphanumeric keypad is used to enter characters directly into editable fields.

- **Numeric fields:** Can only contain numerical values. By pressing a key of the keypad the number will be displayed.
 - **Alphanumeric fields:** Can contain numbers and letters. By pressing a key of the keypad the first character written above that key will be displayed. By pressing several times you can toggle through the characters. For example: 1->S->T->U->1->S....
-

Edit fields



ESC Deletes any change and restores the previous value.

Moves the cursor to the left

Moves the cursor to the right.

Inserts a character at the cursor position.

Deletes the character at the cursor position.



In edit mode the position of the decimal place cannot be changed. The decimal place is skipped.

Special characters

Character	Description
*	Used as wildcards in search fields for point numbers or codes. Refer to "2.6 Pointsearch".
+/-	In the alphanumeric character set "+" and "-" are treated as normal alphanumeric characters with no mathematical function.  "+" / "-" only appear in front of an entry.

APPS 1/3		
F1	SURVEY	(1)
F2	SET OUT	(2)
F3	RESECTION	(3)
F4	COGO	(4)

In this example selecting 2 on an alphanumeric keyboard would start the Set Out application.

2.6 Pointsearch

Description

Pointsearch is a function used by applications to find measured or fixed points in the memory storage.

It is possible to limit the point search to a particular job or to search the whole storage. The search procedure always finds fixed points before measured points that fulfill the same search criteria. If several points meet the search criteria, then the results are ordered according to the entry date. The instrument finds the most recent fixed point first.

Direct search

By entering an actual point number, for example 402, and pressing **SEARCH**, all points within the selected job and with the corresponding point number are found.

```
POINTSEARCH
Job: ██████████ J101
Pt. : ██████████ 402

Select job or enter
point coordinates manually!

SEARCH  COORD
```

SEARCH

To search for matching points within the selected job.

Wildcard search

The wildcard search is indicated by a "*". The asterisk is a place holder for any following sequence of characters. Wildcards should be used if the point number is not fully known, or to search for a batch of points.

Examples of point searches

- * All points are found.
 - A All points with exactly the point number "A" are found.
 - A* All points starting with "A" are found, for example, A9, A15, ABCD, A2A.
 - *1 All points containing only one "1" are found, for example, 1, A1, AB1.
 - A*1 All points starting with "A" and containing only one "1" are found, for example, A1, AB1, A51.
-

3 Operation

3.1 Instrument Setup

Description

This topic describes an instrument setup over a marked ground point using the laser plummet. It is always possible to set up the instrument without the need for a marked ground point.



Important features

- It is always recommended to shield the instrument from direct sunlight and avoid uneven temperatures around the instrument.
- The laser plummet described in this topic is built into the vertical axis of the instrument. It projects a red spot onto the ground, making it appreciably easier to center the instrument.
- The laser plummet cannot be used in conjunction with a tribrach equipped with an optical plummet.

Tripod

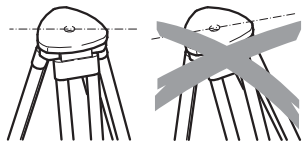

When setting up the tripod pay attention to ensuring a horizontal position of the tripod plate. Slight corrections of inclination can be made with the foot screws of the tribrach. Larger corrections must be done with the tripod legs.

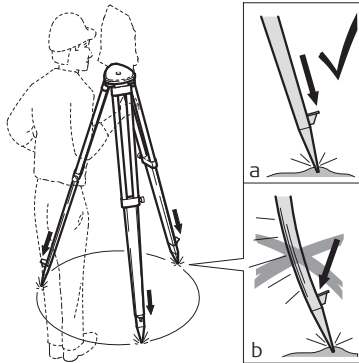

Loosen the clamping screws on the tripod legs, pull out to the required length and tighten the clamps.

- a) In order to guarantee a firm foothold sufficiently press the tripod legs into the ground.
- b) When pressing the legs into the ground note that the force must be applied along the legs.

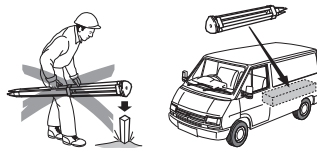

Careful handling of tripod.

- Check all screws and bolts for correct fit.
- During transport always use the cover supplied.
- Use the tripod only for surveying tasks.

Setup step-by-step

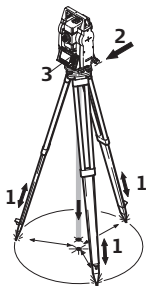

Zoom_004

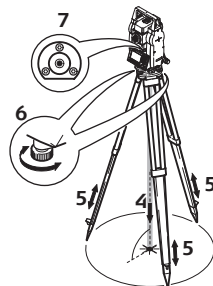

- 1 Extend the tripod legs to allow for a comfortable working posture. Position the tripod over the marked ground point, centring it as best as possible.
- 2 Fasten the tribrach and instrument onto the tripod.
- 3 Turn on the instrument, and, if tilt correction is set to 1- or 2-axis, the laser plummet will be activated automatically, and the **Level & Plummet** screen appears. Otherwise, press **FNC** from within any application and select **Level & Plummet**.
- 4 Move the tripod legs (1) and use the tribrach footscrews (6) to center the plummet (4) over the ground point.
- 5 Adjust the tripod legs (5) to level the circular level (7).
- 6 By using the electronic level, turn the tribrach footscrews (6) to precisely level the instrument. Refer to "Level up with the electronic level step-by-step".

- 7 Center the instrument precisely over the ground point by shifting the tribrach on the tripod plate (2).
- 8 Repeat steps 6 and 7 until the required accuracy is achieved.

Level up with the electronic level step-by-step

The electronic level can be used to precisely level up the instrument using the footscrews of the tribrach.

- 1) Turn the instrument until it is parallel to two footscrews.
- 2) Center the circular level approximately by turning the footscrews of the tribrach.
- 3) Turn on the instrument, and, if tilt correction is set to 1- or 2-axis, the laser plummet will be activated automatically, and the **Level & Plummet** screen appears. Otherwise, press **FNC** from within any application and select **Level & Plummet**.



The bubble of the electronic level and the arrows for the rotating direction of the footscrews only appear if the instrument tilt is inside a certain levelling range.

- Center the electronic level of the first axis by turning the two footscrews. Arrows show the direction of rotation required. When the electronic level is centered the arrows are replaced by checkmarks.

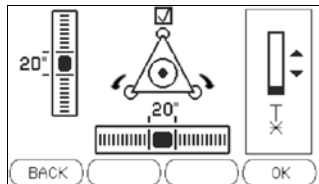

- Center the electronic level for the second axis by turning the last footscrew. An arrow shows the direction of rotation required. When the electronic level is centered the arrow is replaced by a checkmark.

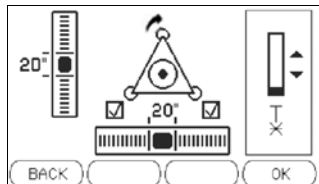

When the electronic level is centered and three checkmarks are shown, the instrument has been perfectly levelled up.

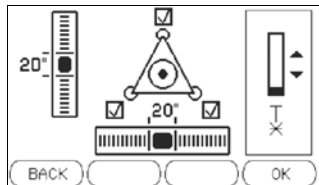

- Accept with **OK**.

Change the intensity of the laser plummet

External influences and the surface conditions may require the adjustment of the intensity of the laser plummet.

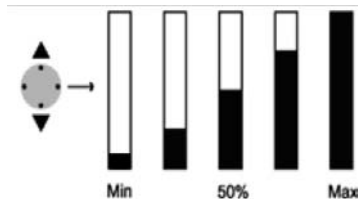

In the **Level & Plummet** screen, adjust the intensity of the laser plummet using the navigation key.

The laser can be adjusted in 25% steps as required.

Position over pipes or holes

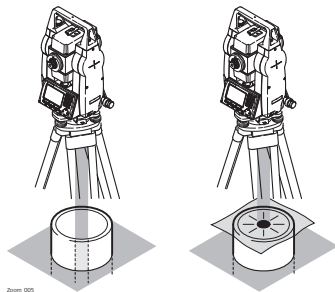

Under some circumstances the laser dot is not visible, for example over pipes. In this case, using a transparent plate enables the laser dot to be seen and then easily aligned to the center of the pipe.

3.2 Working with the Battery



Charging / first-time use

- The battery must be charged prior to using it for the first time because it is delivered with an energy content as low as possible.
- For new batteries or batteries that have been stored for a long time (> three months), it is effectual to make only one charge/discharge cycle.
- The permissible temperature range for charging is between 0°C to +40°C/+32°F to +104°F. For optimal charging we recommend charging the batteries at a low ambient temperature of +10°C to +20°C/+50°F to +68°F if possible.
- It is normal for the battery to become warm during charging. Using the chargers recommended by GeoMax, it is not possible to charge the battery if the temperature is too high.

Operation / discharging

- The batteries can be operated from -20°C to +50°C/-4°F to +122°F.
 - Low operating temperatures reduce the capacity that can be drawn; very high operating temperatures reduce the service life of the battery.
 - For Li-Ion batteries, a single discharging and charging cycle is sufficient. We recommend carrying out the process when the battery capacity indicated on the charger or on a GeoMax product deviates significantly from the actual battery capacity available.
-

Change the battery step-by-step

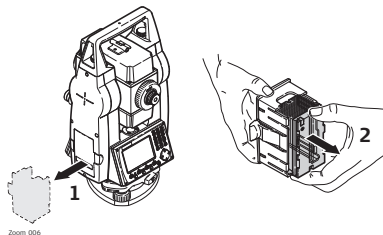

Open the battery compartment (1) and remove the battery holder.

Remove the battery from the battery holder (2).

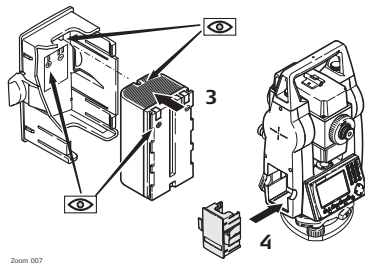

Insert the new battery into the battery holder (3), ensuring that the contacts are facing outward. The battery should click into position.

Insert the battery holder back into the battery compartment (4).



The polarity of the battery is displayed inside the battery housing.

**Warning**

Batteries not recommended by GeoMax may be damaged if charged or discharged. They may burn and explode.

Precautions:

Only charge and discharge batteries recommended by GeoMax.

3.3 Data Storage

Description

An internal memory is included in all instruments. The firmware stores all data in jobs in a database in the internal memory. Data can then be transferred to a computer or other device for post processing via a cable connected to the serial interface RS232 port.

For Zoom 30 instruments, data can also be transferred from the internal memory to a computer or other device via:

- a USB memory stick inserted into the USB host port, or
- via a Bluetooth connection.

Refer to "10 Data Management" for further information on data management and data transfer.

3.4 Main Menu

Description

The **MAIN MENU** is the starting place for accessing all functionality of the instrument. It is usually displayed immediately after the **Level & Plummet** screen, after switching on the instrument.

MAIN MENU

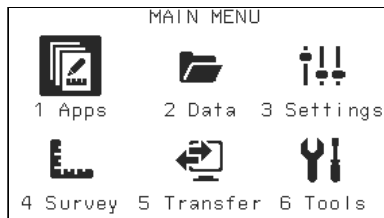

Description of the MAIN MENU functions

Function	Description
Apps	To select and start applications. Refer to "9 Applications".
Data	To manage jobs, data, codelists, formats, system memory and USB memory stick files. Refer to "10 Data Management".

Function	Description
Settings	To change EDM configurations, comm.-setup and general instrument settings. Refer to "4 Settings".
Survey	Survey program to begin measuring immediately. Refer to "3.5 Survey Application".
Transfer	To export and import data. Refer to "10.2 Exporting Data".
Tools	To access instrument related tools such as calibrations, personal start up settings, licence keys and system information. Refer to "5 Tools".



If desired, the instrument can be configured to start in a user defined place after the **Level & Plummet** screen, instead of the **MAIN MENU**. Refer to "5.2 Auto Start Routine".

3.5 Survey Application

Description

After switching on and setting up correctly, the instrument is immediately ready for measuring.

Access

Select **Survey** from the **MAIN MENU**.

SURVEY

SURVEY 1/3	Circular	
Pt. :	P401	1
TgtHGT :	1.500 m	✓
Comment :	-----	
H. A. :	25.7000 g	🗑️
V. A. :	83.2300 g	📢
sDIST :	26.000 m	
<div style="display: flex; justify-content: space-around; border-top: 1px solid black; padding-top: 5px;"> ALL MEAS REC >>> </div>		

>>> CODING

To find/enter codes. Refer to "7 Coding".

>>> STN

To enter station data and set the station.

>>> Set HA

To set the horizontal direction orientation.

>>> HA ← / HA →

To set the horizontal angle reading to the left (anticlockwise) or to the right (clockwise).

The procedure for the quick start **Survey** is identical to the procedure for the application **Survey** available under the **Apps** menu. Therefore this procedure is only described once within the application chapter. Refer to "9.2 Survey".

3.6 Distance Measurements - Guidelines for Correct Results

Description

A laser distancer (EDM) is incorporated into the Zoom instruments. In all versions, the distance can be determined by using a visible red laser beam which emerges coaxially from the telescope objective. There are two EDM modes:

- Prism measurements (IR)
- Reflectorless measurements (RL)

RL measurements

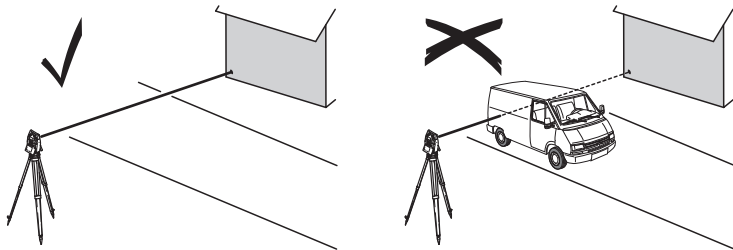

- When a distance measurement is triggered, the EDM measures to the object which is in the beam path at that moment. If a temporary obstruction, for example a passing vehicle, heavy rain, fog or snow is between the

instrument and the point to be measured, the EDM may measure to the obstruction.

- Be sure that the laser beam is not reflected by anything close to the line of sight, for example highly reflective objects.
- Avoid interrupting the measuring beam while taking reflectorless measurements or measurements using reflective foils.
- Do not measure with two instruments to the same target simultaneously.

IR measurements

-
- Accurate measurements to prisms should be made in IR-Default mode.
 - Measurements to strongly reflecting targets such as traffic lights in Prism mode without a prism should be avoided. The measured distances may be wrong or inaccurate.
 - When a distance measurement is triggered, the EDM measures to the object which is in the beam path at that moment. If for example people, cars, animals, or swaying branches cross the laser beam while a measurement is being taken, a fraction of the laser beam is reflected from these objects and may lead to incorrect distance values.
 - Measurements to prisms are only critical if an object crosses the measuring beam at a distance of 0 to 30 m and the distance to be measured is more than 300 m.
 - In practice, because the measuring time is very short, the user can always find a way of avoiding unwanted objects from interfering in the beam path.
-

Red laser to prism

- RL-Long Range mode enables distance measurements of over 3.5 km to standard prisms using the visible red laser beam.

Red laser to reflector foil

- The visible red laser beam can also be used to measure to reflective foils. To guarantee the accuracy the red laser beam must be perpendicular to the reflector foil and it must be well adjusted.
- Make sure the additive constant belongs to the selected target (reflector).



Warning

Due to laser safety regulations and measuring accuracy, using the Long Range Reflectorless EDM is only allowed to prisms that are more than 1000 m (3300 ft) away.

4 Settings

4.1 General Settings

Access

- 1) Select **Settings** from the **MAIN MENU**.
- 2) Select **General** from the **SETTINGS** menu.
- 3) Press  to scroll through the screens of available settings.

SETTINGS

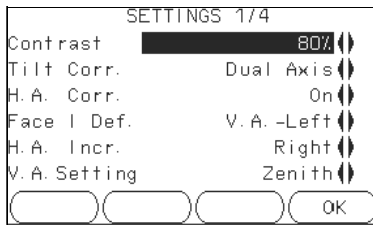

DelLng

To delete a selected language.

Field	Description
Contrast	0% to 100% Sets the display contrast in 10% steps.
Tilt Corr.	Off Tilting compensation deactivated.

Field	Description
	<p>Single Axis Vertical angles refer to the plummet line.</p> <p>Dual Axis Vertical angles refer to the plummet line and the horizontal directions are corrected by the standing axis tilt. For corrections depending on the HA Corr: setting, refer to the table "Tilt and horizontal corrections".</p> <p>If the instrument is used on an unstable base, for example a shaking platform or ship, the compensator should be deactivated. This avoids the compensator drifting out of it's measuring range and interrupting the measuring process by indicating an error.</p>
HA Corr.	<p>On Horizontal corrections are activated. For normal operation the horizontal correction should remain active. Each measured horizontal angle will be corrected, depending on the vertical angle. For corrections depending on the Tilt Corr: setting, refer to the table "Tilt and horizontal corrections".</p> <p>Off Horizontal corrections are deactivated.</p>

Field	Description
Face I Def.	Sets the face I in relation to the position of the vertical drive. VA-Left Sets face I to be when the vertical drive is on the left of the instrument. VA-Right Sets face I to be when the vertical drive is on the right of the instrument.
HA Incr.	Right Set horizontal angle to clockwise direction measurement. Left Set horizontal angle to counter-clockwise direction measurement. Counter-clockwise directions are displayed but are saved as clockwise directions.

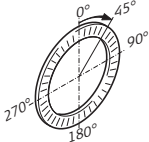
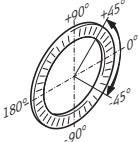
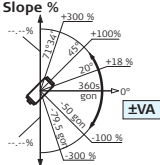
Field	Description
VA-Setting	<p data-bbox="550 184 848 210">Sets the vertical angle.</p> <p data-bbox="550 231 642 256">Zenith</p>  <p data-bbox="958 241 1292 267">Zenith=0°; Horizon=90°.</p> <p data-bbox="550 448 674 474">Horizont</p>  <p data-bbox="950 458 1365 583">Zenith=90°; Horizont=0°. Vertical angles are positive above the horizon and negative below it.</p> <p data-bbox="550 666 671 692">Slope %</p>  <p data-bbox="979 676 1365 903">45° = 100%; Horizont=0°. Vertical angles are expressed in % with positive above the horizon and negative below it. The % value increases rapidly. ---% appears on the display above 300%.</p>

Field	Description
<p data-bbox="368 142 525 171">Angle Unit</p> 	<p data-bbox="547 142 1100 171">Sets the units shown for all angular fields.</p> <p data-bbox="547 189 1275 249"> ° ' " Degree sexagesimal. Possible angle values: 0° to 359°59'59" </p> <p data-bbox="547 272 1246 332"> dec. deg Degree decimal. Possible angle values: 0° to 359.999° </p> <p data-bbox="547 355 1348 415"> gon Gon. Possible angle values: 0 gon to 399.999 gon </p> <p data-bbox="547 438 1319 456"> mil Mil. Possible angle values: 0 to 6399.99mil. </p> <p data-bbox="547 479 1370 570">The setting of the angle units can be changed at any time. The actual displayed values are converted according to the selected unit.</p>
<p data-bbox="368 593 489 648">Min. Reading</p>	<p data-bbox="547 593 1362 684">Sets the number of decimal places shown for all angular fields. This is for data display and does not apply to data export or storage.</p> <p data-bbox="547 707 1297 731">For Angle Unit ° ' ": (0° 00' 01" / 0° 00' 05" / 0° 00' 10").</p> <p data-bbox="746 783 1239 809">Dec.deg: (0.0001 / 0.0005 / 0.001).</p> <p data-bbox="746 831 1180 857">Gon: (0.0001 / 0.0005 / 0.001).</p>

Field	Description
	Mil: (0.01 / 0.05 / 0.1).
Dist. Unit	Sets the units shown for all distance and coordinate related fields. meter Meters [m]. ft (US) US feet [ft]. ft (INT) International feet [fi]. ft-in/16 US feet-inch-1/16 inch [ft].
Temp. Unit	Sets the units shown for all temperature fields. °C Degree Celsius. °F Degree Fahrenheit.
Press.Unit	Sets the units shown for all pressure fields. hPa Hecto Pascal. mbar Millibar. mmHg Millimeter mercury. inHg Inch mercury.

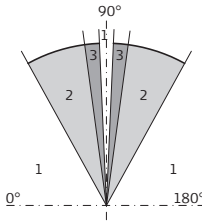
Field	Description
Beep	<p>The beep is an acoustic signal after each key stroke.</p> <p>Normal Normal volume.</p> <p>Loud Increased volume.</p> <p>Off Beep is deactivated.</p>
Sector Beep	<p>On Sector Beep sounds at right angles (0°, 90°, 180°, 270° or 0, 100, 200, 300 gon).</p> <div style="display: flex; align-items: center; justify-content: center;">  <div style="margin-left: 20px;"> <p>1) No beep.</p> <p>2) Fast beep; from 95.0 to 99.5 gon and 105.0 to 100.5 gon.</p> <p>3) Permanent beep; from 99.5 to 99.995 gon and from 100.5 to 100.005 gon.</p> </div> </div> <p>Off Sector Beep is deactivated.</p>
Screen ill.	<p>On or Off Sets the screen illumination on or off.</p>

Field	Description
Crossh ill.	<p>Low, Sets the illumination level of the crosshairs.</p> <p>Medium or</p> <p>High</p>
<p>Heating</p> 	<p>On The display heater is activated.</p> <p>Off The display heater is deactivated.</p> <p>The display heater is automatically activated when the display illumination is on and the instrument temperature is $\leq 5^{\circ}\text{C}$.</p>
Data Output	<p>Sets the location for data storage.</p> <p>Int. Mem. All data is recorded in the internal memory.</p> <p>Interface Data is recorded via the serial interface or the USB device port, depending on the port selected in the COMMUNICATION SETTINGS screen. This Data Output setting is only required if an external storage device is connected and measurements are started at the instrument with MEAS/REC or ALL. This setting is not required if the instrument is totally controlled by a data-logger.</p>

Field	Description
GSI Format	Sets the GSI output format.
	GSI 8 81..00+12345678
	GSI 16 81..00+1234567890123456
Mask	Sets the GSI output mask.
	Mask1 Pt, HA, VA, sDIST, ppm+mm, TgtHGT, Instr.h.
	Mask2 Pt, HA, VA, sDIST, E, N, H, TgtHGT.
Code saving	Sets if the codeblock is saved before or after the measurement. Refer to "7 Coding".
Language	Sets the chosen language. The current loaded language(s) are shown. A selected language can be deleted by pressing DelLng . This function is available if more than one language is installed, and the selected language is not the chosen operating language.
Auto-Off	Enable The instrument switches off after 20 minutes without any activity , for example no key pressed or vertical and horizontal angle deviation is $\leq \pm 3''$.

Field	Description
	Disable Automatic switch-off is deactivated.  Battery discharges quicker.

Tilt and horizontal corrections

Setting		Correction			
Tilt correction	Horizontal correction	Incline longitudinal	Incline transversal	Horizontal collimation	Tilting axis
Off	On	No	No	Yes	Yes
1-Axis	On	Yes	No	Yes	Yes
2-Axis	On	Yes	Yes	Yes	Yes
Off	Off	No	No	No	No
1-Axis	Off	Yes	No	No	No
2-Axis	Off	Yes	No	No	No

4.2 EDM Settings

Description

The settings on this screen define the active EDM, **E**lectronic **D**istance **M**easurement. Different settings for measurements are available with Reflectorless (RL) and Prism (IR) EDM modes.

Access

- 1) Select **Settings** from the **MAIN MENU**.
- 2) Select **EDM** from the **SETTINGS** menu.

EDM SETTINGS

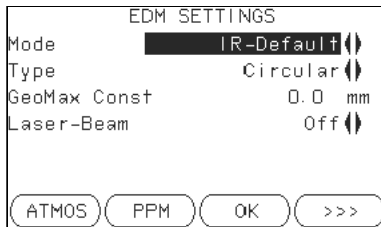

ATMOS

To enter atmospheric data ppm.

PPM

To enter an individual ppm value.

>>> SCALE

To enter projection scale details.

>>> SIGNAL

To view EDM Signal reflection value.

>>> FREQ.

To view the EDM frequency.

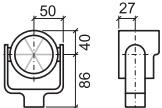
Field	Description	
Mode	IR-Default	Fine measuring mode for high precision measurements with prisms.
	IR-Quick	Quick measuring mode with prisms, with higher measuring speed and reduced accuracy.
	IR-Continuous	For continuous distance measurements with prisms.
	Foil	For distance measurements using Retro reflective targets.
	RL-Default	For distance measurements without prisms.
	RL-Continuous	For continuous distance measurements without prisms.
	RL-Long	For long range distance measurements with prisms.
Type	Circular	 <p data-bbox="947 721 1311 778">Standard prism ZPR100 GeoMax Constant: 0.0 mm</p>

Field	Description	
	Custom	The user can define their own prism. Constants can be entered in mm in GeoMax Const:
	Foil	 GeoMax Constant: +34.4 mm
	None	RL-modes GeoMax Constant: +34.4 mm
GeoMax Const.	This field displays the GeoMax prism constant for the selected Type: Where Type: is Custom this field becomes editable to set a user defined constant. Input can only be made in mm. Limit value: -999.9 mm to +999.9 mm.	
Laser-Beam	Off	Visible laser beam is deactivated.
	On	Visible laser beam for visualising the target point is activated.

ATMOSPHERIC DATA ENTRY

This screen enables the entry of atmospheric parameters. Distance measurement is influenced directly by the atmospheric conditions of the air in which the measurements are taken. In order to take these influences into consider-

ation distance measurements are corrected using atmospheric correction parameters.

The refraction correction is taken into account in the calculation of the height differences and the horizontal distance. Refer to "14.7 Scale Correction" for the application of the values entered in this screen.



When PPM=0 is selected, the GeoMax standard atmosphere of 1013.25 mbar, 12°C, and 60% relative humidity will be applied.

PROJECTION SCALE

This screen enables entry of the scale of projection. Coordinates are corrected with the PPM parameter. Refer to "14.7 Scale Correction" for the application of the values entered in this screen.

Free-PPM Entry

This screen enables the entry of individual scaling factors. Coordinates and distance measurements are corrected with the PPM parameter. Refer to "14.7 Scale Correction" for the application of the values entered in this screen.

EDM SIGNAL REFLECTION

This screen tests the EDM signal strength (reflection strength) in steps of 1%. Enables optimal aiming at distant, barely visible, targets. A percentage bar and a beeping sound, indicate the reflection strength. The faster the beep the stronger the reflection.

4.3 Communication Settings

Description

For data transfer the communication parameters of the instrument must be set.

Access

- 1) Select **Settings** from the **MAIN MENU**.
- 2) Select **Comm** from the **SETTINGS** menu.

COMMUNICA-TION SETTINGS

COMMUNICATION SETTINGS

Port : Bluetooth

Bluetooth: On

Baudrate : 1200

Databits : 8

Parity : None

Stopbits : CR

BTCode [] [] OK

BTCode

To set a code for the Bluetooth connection.



This softkey is only available for Zoom 30 instruments. The default Bluetooth code is '0000'.

Field	Description
Port	Instrument port. For Zoom 30 instruments, the options are selectable. For Zoom 20 instruments, the value is set to RS232 and is uneditable. RS232 Communication is via the serial interface.

Field	Description
	USB Communication is via the USB host port. Bluetooth Communication is via Bluetooth. Automatically Communication is set to auto detect.
Blue-tooth	On Bluetooth sensor is activated. Off Bluetooth sensor is deactivated.

The following fields are active only when **Port: RS232** is set.

Field	Description
Baudrate	Speed of data transfer from receiver to device in bits per second. 1200, 2400, 4800, 9600, 14400, 19200, 38400, 57600, 115200
Databits	Number of bits in a block of digital data. 7 Data transfer is realised with 7 databits. 8 Data transfer is realised with 8 databits.

Field	Description	
Parity	Even	Even parity. Available if data bit is set to 7.
	Odd	Odd parity. Available if data bit is set to 7.
	None	No parity. Available if data bit is set to 8.
Endmark	CR/LF	The terminator is a carriage return followed by a line feed.
	CR	The terminator is a carriage return.
Stopbits	1	Number of bits at the end of a block of digital data.

5 Tools

5.1 Calibration

Description

The **CALIBRATION** menu contains tools to be used for the electronic calibration of the instrument. Using these tools helps to maintain the measuring accuracy of the instrument.

Access

- 1) Select **Tools** from the **MAIN MENU**.
- 2) Select **Calibr.** from the **TOOLS MENU**.
- 3) Select a calibration option from the **CALIBRATION** screen.

Calibration options

In the **CALIBRATION** screen there are several calibration options.

Menu selection	Description
HA-Collimation	Refer to "11.3 Calibrating Line-of-Sight and Vertical Index Error".
Vertical Index	Refer to "11.3 Calibrating Line-of-Sight and Vertical Index Error".
View Calibration Data	Displays the current calibration values that have been set for HA-Collimation and V-index.

5.2 Auto Start Routine

Description

Through the Auto Start tool, it is possible to record a user defined sequence of key presses so that, after switching on the instrument, a particular screen can be displayed after the **Level & Plummet** screen instead of the **MAIN MENU**. For example, the general **SETTINGS** screen for configuring the instrument settings.

Access

- 1) Select **Tools** from the **MAIN MENU**.
 - 2) Select **Auto St.** from the **TOOLS MENU**.
-

Auto start step-by-step

- 1) Press **REC** in the **AUTO START** screen.
 - 2) Press **OK** to confirm the information message and begin the recording process.
 - 3) The next key presses are stored, up to a maximum of 16. To end the recording press **ESC**.
 - 4) If the auto start **Status:** is set to **On**, the stored key presses will be executed automatically after switching on the instrument.
-



The automatic start routine has the same effect as pressing the keys manually. Certain instrument settings can not be made in this way. Relative entries such

as automatically setting EDM **Mode: IR-Quick** upon switching on the instrument, are not possible.

5.3 System Information

Description

The System information screens display instrument, system and firmware information, as well as settings for the date and time.

Access

- 1) Select **Tools** from the **MAIN MENU**.
 - 2) Select **SysInfo** from the **TOOLS MENU**.
-

SYSTEM INFORMATION

This screen displays information about the instrument and operating system.

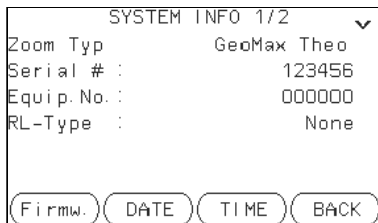

SYSTEM INFO 1/2

Zoom Typ	GeoMax Theo
Serial # :	123456
Equip. No. :	000000
RL-Type :	None

Firmw. DATE TIME BACK

Firmw.

To display details of the firmware package installed on the instrument.

DATE

To change the date and format.

TIME

To change the time.

Next step

Press **Firmw.** to view the firmware package information.



Before selecting **FORMAT**, to format the internal memory, ensure that all important data is first transferred to a computer. Jobs, formats, codelists, configuration files, uploaded languages and firmware will be deleted by formatting.

Field	Description
Zoom-FW. Versi	Displays the firmware version number installed on the instrument.
Build	Displays the build number of the firmware.
Current Lang	Displays the current language and version number selected for the instrument.
EDM-Firmware	Displays the version number of the EDM firmware.
 Application Information	Displays a list of the applications available on the instrument.

5.4 Loading Software

Description

To load application software or an additional language, connect the instrument to GGO via the serial interface and load using "GGO - Software Upload". Refer to the GGO online help for further information.
For Zoom 30 instruments, the software can be loaded via a USB memory stick. This process is described below.

Access

- 1) Select **Tools** from the **MAIN MENU**.
 - 2) Select **Load FW** from the **TOOLS MENU**.
-



- **Load FW** is only an option on the **TOOLS MENU** for Zoom 30 instruments.
 - Never disconnect the power supply during the system upload process. The battery must be at least 75% capacity before commencing the upload.
-

Loading firmware and languages step-by-step

- 1) To load firmware and languages: Select **Zoom Firmware**. The **Select File** screen will appear.
To load only languages: Select **Zoom Languages only** and skip to step 4.
- 2) Select the firmware file from the system folder of the USB memory stick. All firmware and language files must be stored in the system folder to be transferred to the instrument.
- 3) Press **OK**.

- 4 The **Upload Languages** screen will appear displaying all language files in the system folder of the USB memory stick. Select **Yes** or **No** for a language file to be uploaded. At least one language must be set to **Yes**.
 - 5 Press **OK**.
 - 6 Press **Yes** on the power warning message to proceed and upload the firmware and/or selected languages.
 - 7 Once successfully loaded, the system will shutdown and restart again automatically.
-

6 Functions

6.1 Overview

Description

Functions can be accessed by pressing **FNC** from any measurement screen. **FNC** opens the functions menu and a function can be selected and activated.

Functions

Function	Description
Level & Plummet	Activates the laser plummet and electronic level.
Distance Offset	Refer to "6.2 Distance Offset".
RL/IR Change	Changes between the two EDM modes. Refer to "4.2 EDM Settings".
Delete Last Observ.	Deletes the last recorded data block. This can be either a measurement block or a code block.  Deleting the last record is not reversible! Only records recorded in Survey can be deleted.
Code-Library	Starts Coding application to select a code from a codelist or enter a new code. Same functionality like the softkey CODING .
Laserbeam	Activates/deactivates the visible laser beam for illuminating the target point.

Function	Description
Screen ill. On /Off	Activates and deactivates the screen illumination light.
Distance unit	Sets the distance measurement unit.
Angle unit	Sets the angle measurement unit.
Z-Coordinate	Refer to "6.3 Z-Coordinate".
2 Dist. Offset	Refer to "6.4 2 Dist. Offset".
Control Distance	Refer to "6.5 Control Distance".
Settings	Refer to "4.1 General Settings".
EDM Continuous	Refer to "6.6 EDM Continuous".
Menu	Returns to the MAIN MENU .

6.2 Distance Offset

Description

This function calculates the target point coordinates if it is not possible to set up the reflector, or to aim at the target point directly. The offset values (length, trav. and/or height offset) can be entered. The values for the angles and distances are calculated to determine the target point.

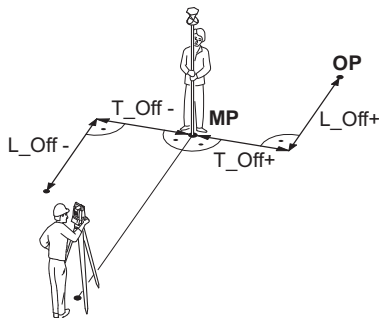

MP	Measurement point
OP	Offset point
T_Off	Length offset
L_Off	Cross offset

Access

- 1) Press **FNC** when within any application.
- 2) Select **Distance Offset** from the **FUNCTIONS** menu.

DIST-OFF

DIST-OFF

Trav. Offset : 2.360 m

Length Offset: 0.000 m

Z-Offset : 0.000 m

Mode 0 after REC

DEFLT

To reset offset values to 0.

Field	Description
Trav. Offset	Perpendicular offset. Positive if the offset point is to the right of the measured point.
Length Offset	Longitudinal offset. Positive if the offset point is further away than the measured point.
Z-Offset	Height offset. Positive if the offset point is higher than the measured point.
Mode	Period for which the offset is to apply. 0 after REC The offset values are reset to 0 after the point is saved. Continuous The offset values are applied to all further measurements.

Field	Description
	The offset values are always reset to 0 when the application is quit.

Next step

- Press **OK** to calculate the corrected values and return to the application from which the offset function was started. The corrected angle and distances are displayed as soon as a valid distance measurement has been triggered or exists.
-

6.3 Z-Coordinate

Description

This function determines the height of the instrument from measurements to a maximum of five target points, with known heights, in two faces. With measurements to several targets, the improvement is indicated in the "d" value.

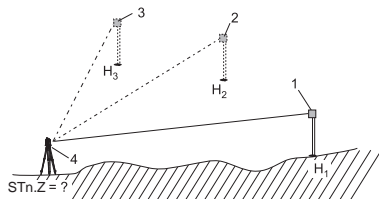

- 1 Reflector 1
- 2 Reflector 2
- 3 Reflector 3
- 4 Instrument

Access

- 1) Press **FNC** when within any application.
- 2) Select **Z-Coordinate** from the **FUNCTIONS** menu.

Z-Coordinate step-by-step

- 1) Select a known point and input the reflector height. Select;
 - **PtHgt:** To enter the height of a fixpoint.
 - **Inst.h.:** To enter the height transfer values for the instrument.

- 2) Press **ALL** to complete the measurement and display the calculated height.
- **AddTg**: Adds another height of a known point.
 - **FACE**: Measures to the same target in second face.
 - **OK**: Saves the changes and sets the station height.
-

6.4 2 Dist. Offset

Description

This function is used for measurements to a point that is not directly visible, using a special 2 Dist. Offset pole.

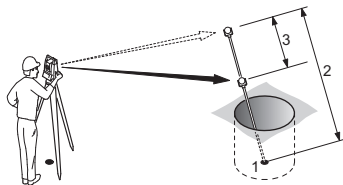

- 1 E, N, H of Target Point
- 2 Pole Length
- 3 Distance P1-P2

Access

- 1) Press **FNC** when within any application.
- 2) Select **2 Dist. Offset** from the **FUNCTIONS** menu.

Next step

If required, press **POLE** to define the pole or EDM settings.

POLE SETTINGS

Field	Description
Mode	Changes the EDM Mode.
Type	Changes the prism type.

Field	Description
GeoMax Const	Displays the prism constant.
Pole Length	Total length of 2 Dist. Offset pole
Dist. P1-P2	Spacing between the centers of the prisms P1 and P2.
Meas. Tol	Limit for the difference between the given and measured spacing of the prisms. If the tolerance value is exceeded, the function will issue a warning.

Next step

In the **2 DIST. OFFSET** screen, measure to the first and second prisms using **ALL** and the **2 DIST. OFFSET RESULT** screen is displayed.

**2 DIST. OFFSET
RESULT**

Displays Easting, Northing and Height coordinates of the target point.

2 DIST. OFFSET RESULT	
Pt. :	P408
E :	21.551 m
N :	10.141 m
Z :	11.865 m
<div style="display: flex; justify-content: space-between; align-items: center;"> END NEW </div>	

END

To record results and return to application where **FNC** was selected.

NEW

To return to the **2 DIST. OFFSET** screen.

Next step

Press **END** to return to the application where **FNC** was selected.

6.5 Control Distance

Description

This function calculates and displays the slope and horizontal distance, height difference, azimuth, grade, and coordinate differences between the last two measured points. Valid distance measurements are required for the calculation.

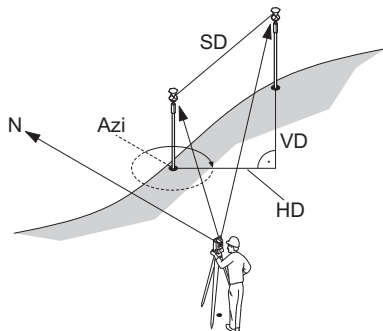

Azi Azimuth
SD Slope distance
VD Height distance
HD Horizontal distance

Access

- 1) Press **FNC** when within any application.
- 2) Select **Control Distance** from the **FUNCTIONS** menu.

CONTROL DISTANCE

Field	Description
Brg	Difference in bearing between the two points.
Grade	Difference in gradient between the two points.
hDIST	Difference in horizontal distance between the two points.
sDIST	Difference in slope distance between the two points.
d.d.Z	Difference in height between the two points.

Messages

The following are important messages or warnings that may appear.

Messages	Description
Less than two valid measurements!	The values cannot be calculated as there are less than two valid measurements.

Next step

Press **OK** to return to the application where **FNC** was selected.

6.6 EDM Continuous

Description

This function activates or deactivates the tracking measurement mode. The new setting is displayed for about one second and then set. The function can only be activated from within the same EDM mode and prism type. The following options are available.

Mode	Off <=> On
IR	IR-Default <=> IR-Continuous / IR-Quick <=> IR-Continuous.
RL	RL-Default <=> RL-Continuous.



The last active measurement mode remains set when the instrument is switched off.

7 Coding

Description

Codes contain information about recorded points. With the help of coding, points can be assigned to a particular group simplifying later processing. Codes are stored in codelists, with each codelist supporting a maximum of 200 codes.

GSI coding

Codes are always stored as free codes (WI41-49), that means that codes are not directly linked to a point. They are stored before or after the measurement depending on the setting made. Point codes (WI71-79) are not available. A code is always recorded for each measurement as long as the code is displayed in the **Code:** field. For a code not to be recorded, the **Code:** field must be cleared. This can be set to occur automatically. Refer to "4.1 General Settings".

Access

- Either, select **Survey** from the **MAIN MENU** and press >>> **CODING**.
 - Or, press **FNC** when within any application and select **Code Library**.
-

CODE-LIBRARY

CODE-LIBRARY 1/2

Search/New:

Code : 552

Comment : CODEDESC

Text 1 : -----

Text 2 : -----

REC AddLst OK

REC

To record the code without measurement.

AddLst

To add the entered code to the codelist.

Field	Description
Search/New	Code name. After entry, the firmware searches for a matching code name, and displays these in the code field. If a matching code name doesn't exist this value becomes the new code name.
Code	List of existing code names.
Comment	Additional remarks.
Text1 to Text8	More information lines, freely editable. Used to describe attributes of the code.

**Extend / edit
codes**

To each code a description and a maximum of 8 attributes with up to 16 characters each can be assigned. Existing code attributes, displayed in fields **Text 1:** to **Text 8:**, can be overwritten freely with the following exceptions: The codelist editor of GGO can assign a status to the attributes.

- Attributes with status "fixed" are write-protected. They cannot be overwritten or edited.
 - For attributes with status "Mandatory" an input or a confirmation is required.
 - Attributes with status "Normal" can be edited freely.
-

8 Applications - Getting Started

8.1 Overview

Description

Applications are predefined programs, that cover a wide spectrum of surveying duties and facilitate daily work in the field. The following applications are available, although application packages for each instrument may vary from that stated below:

- Survey
 - Reference Element
 - COGO
 - Missing Line Measurement
 - Resection
 - Set Out
 - Area & Volume
 - Remote Elevation
 - Construction
-

8.2 Starting an Application

Access

- 1) Select **Apps** from the **MAIN MENU**.
- 2) Press  to move through the screens of available applications.
- 3) Press a function key, **F1 - F4**, to select the specified application in the **APPS** menu.

Pre-settings screens

Pre-settings for Survey is shown as an example. Any additional settings for particular applications are explained within the chapters for those applications.

SURVEY			
[*]	F1	Select Job	(1)
[*]	F2	Select Station	(2)
[]	F3	Select Orientn.	(3)
	F4	GO!	(4)
<div style="display: flex; justify-content: space-around; margin-top: 10px;"> F1 F2 F3 F4 </div>			

[•] = Setting has been made.
 [] = Setting has not been made.

F1-F4

To select menu item.

Field	Description
Select Job	To define the job where data will be saved. Refer to "8.3 Selecting the Job".

Field	Description
Select Station	To define the current position of the instrument station. Refer to "8.4 Selecting the Station".
Select Orientn.	To define the orientation, horizontal direction, of the instrument station. Refer to "8.5 Selecting the Orientation".
Go!	Starts the selected application.

8.3 Selecting the Job

Description

All data is saved in Jobs, like file directories. Jobs contain measurement data of different types, for example measurements, codes, fixed points, or stations. Jobs are individually manageable and can be exported, edited or deleted separately.

Access

Select **Select Job** in **Pre-settings** screen.

SELECT JOB

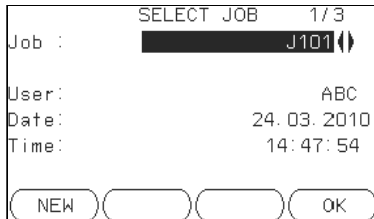

NEW

To create a new job.

Field	Description
Job	Name of an existing job to be used.
User	Name of user, if entered.
Date	Date the selected job was created.

Field	Description
Time	Time the selected job was created.

Next step

- Either, press **OK** to continue with the selected job.
 - Or, press **NEW** to open the **NEW JOB** screen and create a new job.
-

Recorded data

Once a job is set up, all subsequent recorded data will be stored in this job. If no job was defined and an application was started, or if in **Survey** and a measurement was recorded, then the system automatically creates a new job and names it "DEFAULT".

Next step

Press **OK** to confirm the job and return to the **Pre-Settings** screen.

8.4 Selecting the Station

Description

All measurements and coordinate computations are referenced to the set station coordinates.

The station coordinates that are set must include:

- at least grid coordinates (E, N), and
- the station height, if required.

The coordinates can be entered manually or selected from the memory.

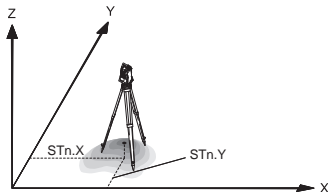

Directions

- X Easting
- Y Northing
- Z Height

Station coordinates

- Stn.X Easting coordinate of station
- Stn.Y Northing coordinate of station

Access

Select **Select Station** in the **Pre-settings** screen.

Station input

Field	Description
Stn	Station name of a previously saved station position.



If no station was set and an application was started, or if in **Survey** and a measurement was recorded, then the last station is set as the current station.

Next step

The **Inst.H.** field appears once the station coordinates have been entered. Enter the instrument height if desired and press **OK** to return to the **Pre-Settings** screen.

8.5 Selecting the Orientation

8.5.1 Overview

Description

All measurements and coordinate computations are referenced to the orientation of the set station. The orientation can be entered manually or determined from points that are either measured or selected from the memory.

Access

Select **Select Orientn.** in the **Pre-settings** screen and choose:

- **Angle** To enter a new bearing. Refer to "8.5.2 Manual Orientation".
 - **Coordinates** To calculate and set the orientation using existing coordinates. A maximum of five target points can be used. Refer to "8.5.3 Orientation with Coordinates".
-

8.5.2 Manual Orientation

Access

Select **Angle** in the **STN.ORIENTATION** screen.

MANUAL ANGLE SETTING

MANUAL ANGLE SETTING	
Brg. :	0.0000 g
TgtHGT:	1.500 m
BS ID :	301
ALL REC H. A. =0 EDM	

HA=0

To set **Brg: 0**

Field	Description
Brg	Horizontal direction of the station.
TgtHGT.	Height of the reflector.
BS ID	Point ID of the backsight point.

Next step

- Either, press **ALL** to measure and record the distance and horizontal angles. This will calculate and set the orientation and return to the **Pre-Settings** screen.
 - Or, press **REC** to record the horizontal direction only. This will set the orientation and return to the **Pre-Settings** screen.
-

8.5.3 Orientation with Coordinates

Diagram

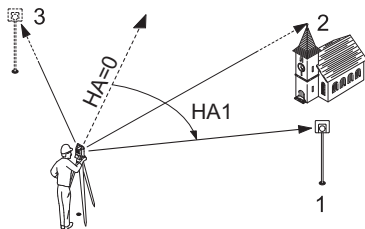

Known coordinates

- 1 Target point
- 2 Target point
- 3 Target point

Calculations

- HA1 Station orientation

Access

Select **Coordinates** in the **STN-ORIENTATION** screen.

Orientation with coordinates

Field	Description
Pt.	Point ID of the backsight point.

Next step

Find an existing backsight point in the pointsearch or enter ENZ coordinates for a new point. Press **OK** to continue to **Sight target point**.

Sight target point

Field	Description
BS ID	Point ID of the selected, or entered backsight point.

Next step

After each measurement the message, **Do you want to take additional measurements** appears. Selecting:

- **Yes** returns to the **Sight target point** screen to take an additional measurement. A maximum of five target points can be used.
- **No** proceeds to the **STN. ORIENTATION RESULT** screen.

Result calculation

If more than one target point is measured then the orientation is computed using the "least squares method".

IF	THEN
the orientation is only measured in face II	the horizontal direction is based on face II.
the orientation is measured only in face I or a mixture of I and II	the horizontal direction is based on face I.
a target point is measured several times in the same face	the last valid measurement is used for the computation.

Stn. Orientation result

Field	Description
Pts	Number of points used in the calculation.
Stn	Station name for which the orientation has been set.
HA Corr	Horizontal correction
Std.Dev	Standard deviation indicating the potential variance between the true orientation and that calculated.

Next step

- Either, press **Resid** to display the residuals.
- Or, press **OK** to set the orientation and return to the **Pre-Settings** screen.

Stn. Orientation Residuals

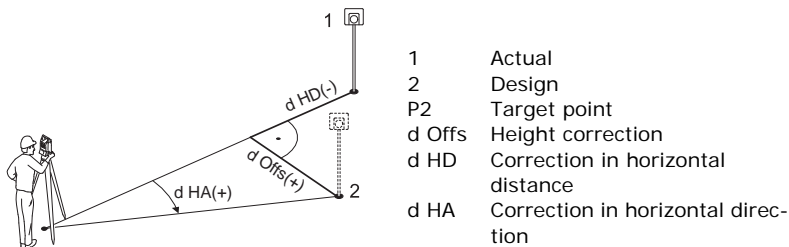

Field	Description
BS ID	Point IDs of the target points used in calculating the orientation.
d.H.A	The difference in horizontal direction to the target point.
d.H.D	The difference in horizontal distance to the target point.
dZ	The difference in height to the target point.



If no orientation was set and an application was started, or if in **Survey** and a measurement was recorded, then the current horizontal direction is set as the orientation.

Next step

Select **GO!** to begin the application.

9 Applications

9.1 Common Fields

Description of fields

The following table describes common fields that are found within the firmware applications. These fields are described here once and not repeated in the application chapters unless the field has a specific meaning within that application.

Field	Description
Pt, Pt 1	Point ID of the point.
TgtHGT	Height of the reflector.
HA	Horizontal direction to the point.
VA	Vertical angle to the point.
hDIST	Horizontal distance to the point.
sDIST	Slope distance to the point.
dHGT	Height to the point.
E	Easting coordinate of the point.
N	Northing coordinate of the point.
Z	Height coordinate of the point.

9.2 Survey

Description

Survey is an application used for the measurement of an unlimited number of points. It is comparable to **Survey** from the **MAIN MENU**, but includes pre-settings for the job, station and orientation prior to beginning a survey.

Access

- 1) Select **Apps** from the **MAIN MENU**.
- 2) Select **Survey** from the **APPS** menu.
- 3) Complete application pre-settings. Refer to "8 Applications - Getting Started".

SURVEY

SURVEY 1/3	Circular	
Pt. :	P401	1
TgtHGT :	1.500 m	✓
Comment :	-----	
H. A. :	25.7000 g	🗑️
V. A. :	83.2300 g	🔊
sDIST :	26.000 m	
<div style="display: flex; justify-content: space-around; border: 1px solid black; border-radius: 10px; padding: 5px;"> ALL MEAS REC >>> </div>		

>>> I Pt

To switch between individual and current point numbers.

>>> CODING

To find/enter codes. Refer to "7 Coding".

Field	Description
Comment / Code	Comment or Code name depending on the coding method. Two coding methods are available: 1) Comment coding: This text is stored with the corresponding measurement. The code is not related to a codelist, it is just a simple comment. A codelist on the instrument is not necessary. 2) Expanded coding with codelist: Press >>> CODING . The code that was entered is searched for within the code list and it is possible to add attributes to the code.

Next step

- Either, press **ALL** to record another point.
 - Or, press **ESC** to exit the application.
-

9.3 Reference Element - Reference Line

9.3.1 Overview

Description

Reference Element - Line is an application that facilitates the easy set out or checking of lines, for example, for buildings, sections of road, or simple excavations. It allows the user to define a reference line and then complete the following tasks with respect to that line:

- Line & offset
- Set out points

Access

- 1) Select **Apps** from the **MAIN MENU**.
- 2) Select **Reference Element** from the **APPS** menu.
- 3) Complete application pre-settings. Refer to "8 Applications - Getting Started".
- 4) Select **Line**

Next step

Define the base line for the reference line.

9.3.2 Defining the Base Line

Description

A reference line can be defined by referencing a known base line. The reference line can be offset either longitudinally, in parallel or vertically to the base line, or be rotated around the first base point as required. Furthermore the reference height can be selected as the first point, second point or interpolated along the reference line.

Define the base line

The base line is fixed by two base points. All points can be either measured, manually entered, or selected from the memory.

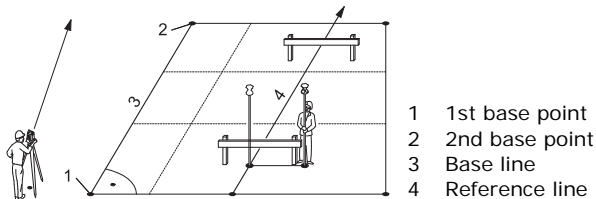

Define the base line by measuring or selecting the start and end points of the line.

Next step

After defining the base line the **REFERENCE LINE** screen will appear for defining the reference line.

9.3.3 Defining the Reference Line

Description

The base line can be offset from, either longitudinally, in parallel or vertically, or be rotated around the first base point. This new line created from the offsets is called the reference line. All measured data refers to the reference line.

Reference line

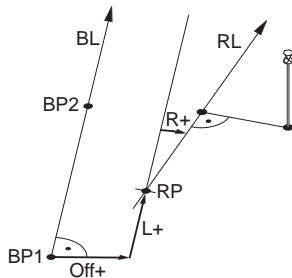

BP	Base point
BL	Base line
RP	Reference point
RL	Reference line
Off	Parallel offset
L	Longitudinal offset
R	Rotation parameter

Access

After completing the measurements required for defining the base line, the **REFERENCE LINE** screen will appear.

REFERENCE LINE

REFERENCE LINE 1/2	
Length:	35.497 m
Shifts:	
Offset:	0.250 m
Line :	1.580 m
Z :	0.000 m
Rotate:	0.0000 g
New MEAS SETOUT	

New

To define a new base line.

MEAS

To measure Line & Offset.

SETOUT

To set out points orthogonal to the reference line.

Field	Description
Length	Length of the base line.
Offset	Parallel offset of the reference line relative to the base line (P1-P2). Positive values are to the right of the base line.
Line	Longitudinal offset of the start point, reference point (P3), of the reference line in the direction of base point 2. Positive values are towards base point 2.
Z	Height offset of the reference line to the selected reference height. Positive values are higher than the selected reference height.
Rotate	Rotation of the reference line clockwise around the reference point (P3).

Field	Description	
Ref.Hgt	Pt. 1	Height differences are computed relative to the height of the first reference point.
	Pt. 2	Height differences are computed relative to the height of the second reference point.
	Interpolated	Height differences are computed along the reference line.
	w/o. Height	Height differences are not computed or shown.

Next step

Select a softkey option, **MEAS** or **SETOUT** to proceed to a subapplication.

9.3.4 Subapplication Measure Line & Offset

Description

The Measure Line & Offset subapplication calculates from measurements or coordinates, longitudinal offsets, parallel offsets and height differences of the target point relative to the reference line.

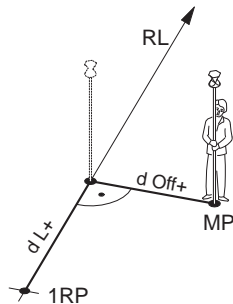

- RL Reference line
- 1RP Start point
- MP Measured point
- dL Longitudinal offset
- dOff Parallel offset

Example of height difference relative to first reference point

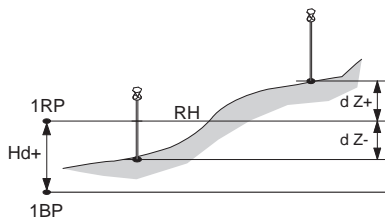

- 1RP 1st reference point
- 1BP 1st base point
- RH Reference height
- Hd Height difference between reference and base point
- d Z Height difference from reference height

Access

Press **MEAS** in the **REFERENCE LINE** screen.

Measure

Field	Description
d Line	Calculated distance longitudinal to the reference line.
d Offset	Calculated distance perpendicular from the reference line.
d.d.Z	Calculated height difference relative to the defined reference height.

Next step

- Either, press **ALL** to measure and record.
- Or, press >>> **BACK** to return to the **REFERENCE LINE** screen.

9.3.5 Subapplication Setout

Description

The setout subapplication calculates the difference between a measured point and the calculated point. The orthogonal (dLine, dOffset, d.d.Z) and polar (dHA, d.hDIST, d.d.Z) differences are displayed.

Example orthogonal setout

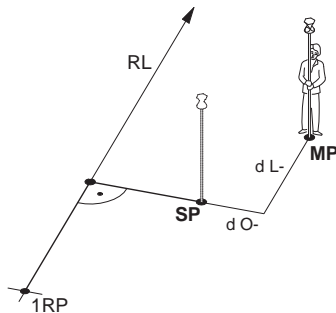

- 1RP 1st reference point
- SP Set out point
- MP Measured point
- RL Reference line
- dL Longitudinal offset
- dO Parallel offset

Access

Press **SETOUT** from the **REFERENCE LINE** screen.

SETOUT

Enter the set out elements for the target points to be set out relative to the reference line.

Field	Description
Line	Longitudinal offset: Positive if set out point is further away from the reference line.
Offset	Perpendicular offset: Positive if set out point is to the right of the reference line.
Z	Height offset: Positive if set out point is higher than the reference line.

Next step

Press **OK** to proceed to measurement mode.

SET OUT

The signs for the distance and angle differences are correction values (required minus actual). The arrows indicate the direction to move to get to the set out point.

SETOUT 1/2			
Pt. :		P414	1
TgtHGT:		1.500 m	✓
dH. A. :	←	-0.6764 g	U
d. H. D. :	↓	-2.371 m	U
d. d. Z. :	↑	0.082 m	
[ALL] [MEAS] [REC] [>>>]			

>>> **NextPt**

To add the next point to be set out.

Field	Description
d HA	Horizontal direction from the measured point to the set out point. Positive if the telescope must be turned clockwise to the set out point.
d.H.D	Horizontal distance from the measured point to the set out point. Positive if the set out point is further away than the measured point.
d.d.Z	Height difference from the measured point to the set out point. Positive if the set out point is higher than the measured point.

Field	Description
dOffset	Perpendicular distance from the measured point to the set out point. Positive if the set out point is to the right of the measured point.
dLine	Longitudinal distance from the measured point to the set out point. Positive if the set out point is further away than the measured point.

Messages

The following are important messages or warnings that may appear.

Messages	Description
Base line too short !	Base line is shorter than 1 cm. Choose base points such that the horizontal separation of both points is at least 1 cm.
Coordinates invalid !	No coordinates or invalid coordinates for a point. Ensure that points used have at least Easting and Northing coordinates.
Save via RS232 !	Data Output: is set to RS232 in the SETTINGS menu. To be able to successfully start reference element, Data Output: must be set to Internal .

Next step

- Either, press **ALL** to measure and record.
 - Or, press >>> **BACK** to return to the **REFERENCE LINE** screen.
 - Or, continue selecting **ESC** to exit the application.
-

9.4 Reference Element - Reference Arc

9.4.1 Overview

Description

The Reference Element - Arc application allows the user to define a reference arc and then complete the following tasks with respect to the arc:

- Line & offset
- Set out (Point, Arc, Chord, Angle)

Access

- 1) Select **Apps** from the **MAIN MENU**.
- 2) Select **Reference Element** from the **APPS** menu.
- 3) Complete application pre-settings. Refer to "8 Applications - Getting Started".
- 4) Select **Arc**.

Next step

Define the reference arc.

9.4.2 Defining the Reference Arc

Description

The reference arc can be defined by a center point and start point, or a start point, end point, and radius. All points can be either measured, manually entered, or selected from the memory.

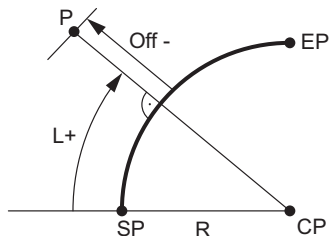

SP	Start point
EP	End point
CP	Center point
R	Radius of arc
L	Distance from start of arc, following curve
Off	Perpendicular distance from arc



All arcs are defined in a clockwise direction and all calculations are made in two dimensions.

Access

Select **Arc** and then the method to define the arc by:

- **Start-/ Centre Pt.**
- **Start-/ End Pt/ Rad.**

Reference Arc - Measure to start point

Field	Description
Start Pt	Point ID of the start point.
C-Pt	Point ID of the center point.
End Pt	Point ID of the end point.
Radius	Radius of the arc.

Next step

After defining the reference arc the **REFERENCE ARC** screen will appear.

REFERENCE ARC

REFERENCE ARC	
StartPt:	P410
EndPt :	P411
CtrPt :	-----
Radius :	32.000 m
<div style="display: flex; justify-content: space-around; margin-top: 10px;"> New MEAS SETOUT </div>	

New

To define a new base arc.

MEAS

To measure Line & Offset.

SET OUT

To set out.

Next step

Select a softkey option, **MEAS** or **SET OUT**, to proceed a subapplication.

9.4.3 Subapplication Measure Line & Offset

Description

The Measure Line & Offset subapplication calculates from measurements or coordinates, longitudinal and orthogonal offsets and height differences of the target point relative to the reference arc.

Access

Press **MEAS** from the **REFERENCE ARC** screen.

Measure

Field	Description
dLine	Calculated distance longitudinal to the reference arc.
dOffset	Calculated distance perpendicular from the reference arc.
d.d.Z	Calculated height difference relative to the start point of reference arc.

Next step

- Either, press **ALL** to measure and record.
 - Or, press >>> **BACK** to return to the **REFERENCE ARC** screen.
-

9.4.4 Subapplication Setout

Description

The setout subapplication calculates the difference between a measured point and the calculated point. The reference arc application supports four ways to set out:

- Set out point
- Set out arc
- Set out chord
- Set out angle

Set out point

To set out a point by entering a line and an offset value.

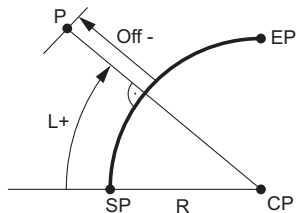

- CP Center point of arc
- SP Start point of arc
- EP End point of arc
- P Set out point
- R Radius of arc
- L Line offset
- Off Perpendicular offset

Set out arc

To set out a series of equidistant points along the arc.

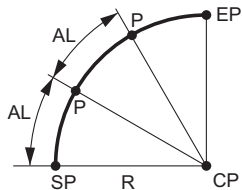

- CP Center point of arc
- SP Start point of arc
- EP End point of arc
- P Set out point(s)
- R Radius of arc
- AL Arc length

Set out chord

To set out a series of equidistant chords along the arc.

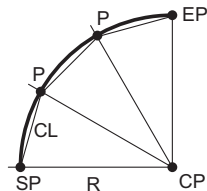

- CP Center point of arc
- SP Start point of arc
- EP End point of arc
- P Set out point(s)
- R Radius of arc
- CL Chord length

Set out angle

To set out a series of points along the arc defined by the angle segments from the center point of the arc.

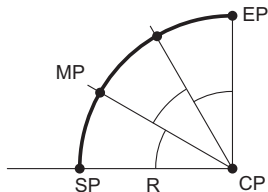

- CP Center point of arc
- SP Start point of arc
- EP End point of arc
- MP Measured point
- R Radius of arc
- b Central angle

Access

- 1) Press **SET OUT** from the **REFERENCE ARC** screen.
- 2) Select one of the four methods of set out available.

Set out point, arc, chord or angle

Enter the set out values. Press **PrevPt/NextPt** to toggle through the calculated set out points.

Field	Description
Distrib.	For set out arc: Method of misclosure distribution. If the entered arc length is not an integer of the whole arc, there will be a misclosure.
None	All of the misclosure will be added to the last arc-section.

Field	Description
	<p>Equal The misclosure will be equally distributed between all sections.</p> <p>Start Arc All of the misclosure will be added to the first arc-section.</p>
Arc Length	For set out arc: The length of the arc-segment to set out.
Chord Length	For set out chord: The length of the chord to set out.
Angle	For set out angle: The angle around the center point of the arc, of the points to be set out.
Line	<p>For set out arc, chord and angle: Longitudinal offset from the reference arc. This is calculated by the arc length, chord length or angle and the selected misclosure distribution.</p> <p>For set out point: Longitudinal offset from the reference arc.</p>
Offset	Perpendicular offset from the reference arc.

Next step

Press **OK** to proceed to measurement mode.

**REFERENCE ARC -
SET OUT**

The signs for the distance and angle differences are correction values (required minus actual). The arrows indicate the direction to move to get to the set out point.

REFERENCE ARC - SETOUT			
Pt. :		P412	1
TgtHGT:		1.500 m	✓
dH. A. :	→	+0.9852 g	
d. H. D. :	↓	-0.514 m	🗑️
d. d. Z. :	↑	0.082 m	🔍
<div style="display: flex; justify-content: space-around; margin-top: 10px;"> MEAS REC NextPt >>> </div>			

NextPt

To add the next point to be set out.

Field	Description
d HA	Horizontal direction from the measured point to the set out point. Positive if the telescope must be turned clockwise to the set out point.
d.H.D	Horizontal distance from the measured point to the set out point. Positive if the set out point is further away than the measured point.
d.d.Z	Height difference from the measured point to the set out point. Positive if the set out point is higher than the measured point.

Next step

- Either, press >>> **ALL** to measure and record.
 - Or, press >>> **BACK** to return to the **REFERENCE ARC** screen.
 - Or, continue selecting **ESC** to exit the application.
-

9.5 COGO

9.5.1 Starting COGO

Description

COGO is an application used to perform **co**ordinate **g**eometry calculations such as, coordinates of points, bearings between points and distances between points

The COGO calculation methods are:

- Inverse and Traverse
 - Intersections
 - Offset
 - Extension
-

Access

- 1) Select **Apps** from the **MAIN MENU**.
 - 2) Select **COGO** from the **APPS** menu.
 - 3) Complete application pre-settings. Refer to "8 Applications - Getting Started".
 - 4) Select from the **COGO MAIN MENU**:
 - **Inverse & Traverse**
 - **Intersection**
 - **Offset**
 - **Extension**
-

9.5.2 Inverse and Traverse

Access

- 1) Select **Inverse & Traverse** from the **COGO MAIN MENU**.
- 2) Select **Inverse** or **Traverse**.

Inverse

Use the inverse subapplication to calculate the distance, direction, height difference and grade between two known points.

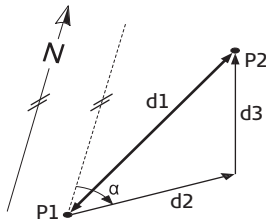

Known

- P1 First known point
- P2 Second known point

Unknown

- α Direction from P1 to P2
- d1 Slope distance between P1 and P2
- d2 Horizontal distance between P1 and P2
- d3 Height difference between P1 and P2

Traverse

Use the traverse subapplication to calculate the position of a new point using the bearing and the distance from a known point. Offset optional.

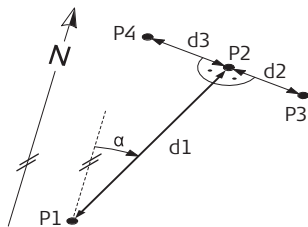
Known

- P1 Known point
- α Direction from P1 to P2
- d1 Distance between P1 and P2
- d2 Positive offset to the right
- d3 Negative offset to the left

Unknown

- P2 COGO point without offset
- P3 COGO point with positive offset
- P4 COGO point with negative offset

9.5.3 Intersections

Access

- 1) Select **Intersection** from the **COGO MAIN MENU**.
- 2) Select the desired COGO method:
 - **Brg-Brg**
 - **Brg-Dst**
 - **Dst-Dst**
 - **Ln-Ln**

Bearing-Bearing

Use the bearing-bearing subapplication to calculate the intersection point of two lines. A line is defined by a point and a direction.

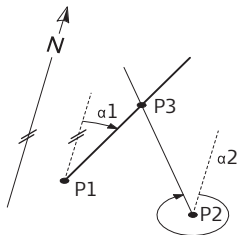

Known

- P1 First known point
- P2 Second known point
- α_1 Direction from P1 to P3
- α_2 Direction from P2 to P3

Unknown

- P3 COGO point

Bearing-Distance

Use the bearing-distance subapplication to calculate the intersection point of a line and a circle. The line is defined by a point and a direction. The circle is defined by the center point and the radius.

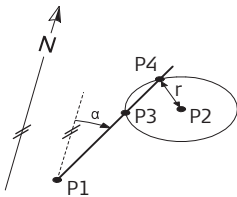
Known

- P1 First known point
- P2 Second known point
- α Direction from P1 to P3 and P4
- r Radius, as the distance from P2 to P4 or P3

Unknown

- P3 First COGO point
- P4 Second COGO point

Distance-Distance

Use the distance-distance subapplication to calculate the intersection point of two circles. The circles are defined by the known point as the center point and the distance from the known point to the COGO point as the radius.

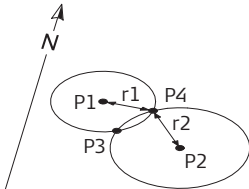
Known

- P1 First known point
- P2 Second known point
- $r1$ Radius, as the distance from P1 to P3 or P4
- $r2$ Radius, as the distance from P2 to P3 or P4

Unknown

- P3 First COGO point
- P4 Second COGO point

By Points

Use the line-line subapplication to calculate the intersection point of two lines. A line is defined by two points.

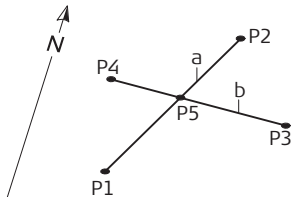

Known

- P1 First known point
- P2 Second known point
- P3 Third known point
- P4 Fourth known point
- a Line from P1 to P2
- b Line from P3 to P4

Unknown

- P5 COGO point

9.5.4 Offsets

Access

- 1) Select **Offset** from the **COGO MAIN MENU**.
- 2) Select the desired COGO method:
 - **DistOff**
 - **Set Pt**

Distance - Offset

Use the distance-offset subapplication to calculate the distance and offset of a known point, with the basepoint in relation to a line.

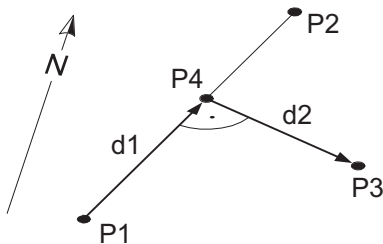

Known

- P0 Instrument station
- P1 Start point
- P2 End point
- P3 Offset point

Unknown

- d1 d Line
- d2 d Offset
- P4 COGO (base) point

Set point by....

Use the set point subapplication to calculate the coordinates of a new point in relation to a line from known longitudinal and offset distances.

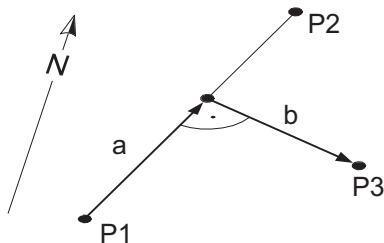

Known

- P0 Instrument station
- P1 Start point
- P2 End point
- d1 d Line
- d2 d Offset

Unknown

- P3 COGO point

9.5.5 Extension

Access

Select **Extension** from the **COGO MAIN MENU**.

Extension

Use the Extension subapplication to calculate the extended point from a known base line.

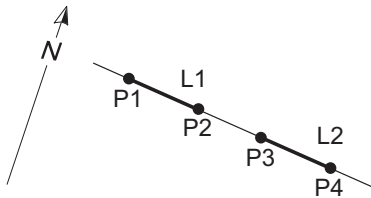

Known

P1 Baseline start point

P3 Baseline end point

dL1, dL2 Distance

Unknown

P2, P4 Extended COGO points

9.6 Missing Line Measurement

Description

Missing Line Measurement is an application used to compute slope distance, horizontal distance, height difference and azimuth of two target points which are either measured, selected from the memory, or entered using the keypad.

Missing Line Measurement methods

The user can choose between two different methods:

- Polygonal: P1-P2, P2-P3, P3-P4.
- Radial: P1-P2, P1-P3, P1-P4.

Polygonal method

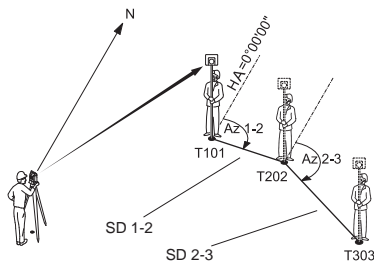

T101	1st target point
T202	2nd target point
T303	3rd target point
SD 1-2	Slope distance from T101-T202
SD 2-3	Slope distance from T202-T303
Az 1-2	Azimuth from T101-T202
Az 2-3	Azimuth from T202-T303

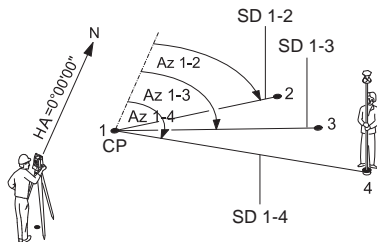
Radial method

1-4	Target points
SD 1-2	Slope distance from 1-2
SD 1-3	Slope distance from 1-3
SD 1-4	Slope distance from 1-4
Az 1-2	Azimuth from 1-2
Az 1-3	Azimuth from 1-3
Az 1-4	Azimuth from 1-4
CP	Center point

Access

- 1) Select **Apps** from the **MAIN MENU**.
- 2) Select **Missing Line Meas.** from the **APPS** menu.
- 3) Complete application pre-settings. Refer to "8 Applications - Getting Started".
- 4) Select **Polygon** or **Radial**.

Missing line measurements

After completing the measurements required, the **MLM RESULT** screen will appear.

MISSING LINE RESULT - Poly- gonal method

MISSING LINE RESULT	
Pt 1 :	P415
Pt 2 :	P416
Grade :	+2.9%
d. S. D. :	3.534 m
d. H. D. :	3.533 m
Brg. Z. :	136.9971 g
<input type="button" value="NewPt1"/>	<input type="button" value="NewPt2"/>
<input type="button" value=""/>	<input type="button" value="RADIAL"/>

NewPt 1

To calculate an additional line.
Application starts again at point 1.

NewPt 2

To set point 2 as the starting point
of a new line. A new point 2 must
be measured.

RADIAL

To switch to radial method.

Field	Description
Grade	Grade [%] between point 1 and point 2.
d.S.D	Slope distance between point 1 and point 2.
d.H.D	Horizontal distance between point 1 and point 2.
d.d.Z	Height difference between point 1 and point 2.
Brg	Azimuth between point 1 and point 2.

Next step

Press **ESC** to exit the application.

9.7 Resection

9.7.1 Starting Resection

Description

Resection is an application used to determine the instruments position from measurements to known points. A minimum of two known points and a maximum of 5, can be used to determine the position.

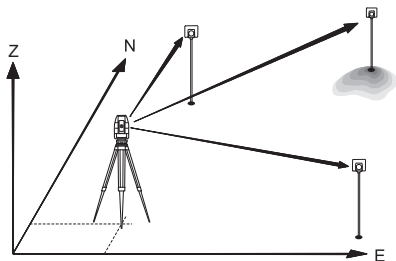

Access

- 1) Select **Apps** from the **MAIN MENU**.
- 2) Select **Resection** from the **APPS** menu.
- 3) Complete application pre-settings. Refer to "8 Applications - Getting Started".

- 4) **Select Accuracy Limit:**
 - **Status: On** to activate a warning message if the calculated standard deviation exceeds the limit.
 - Set the accuracy limits for the Easting, Northing and Height coordinates and the standard deviation angle.
 - Press **OK** to save the limits and return to the **Pre-settings** screen.
 - 5) Select **GO!** to begin the application.
-

Enter target data

Enter the name of the station and the height of the instrument in the **Station data** screen and press **OK**.

Next step

To access the **Sight target point** screen:

- Either, press **OK** after entering the target data fields in the **Target data** screen.
 - Or, press >>> **SKIP** to skip entering the target data fields again when measuring the same point in another face.
-

Sight target point

In the **Sight target point** screen:

2 / I: Indicates that the second point was measured in face I.

2 / I II: Indicates that the second point was measured in faces I and II.

		2 / I	
Pt. :		P404	2
TgtHGT :		1.500 m	↓
H. A. :		302.6000 g	
V. A. :		287.2000 g	⊗
hDIST :		31.355 m	⊗
<input type="button" value="ALL"/> <input type="button" value="NextPt"/> <input type="button" value="CALC."/> <input type="button" value=">>>"/>			

CALC.

To calculate and display the station coordinates, if at least two points and a distance were measured.

NextPt

To return to the **Enter target data** screen to select the next known point.

Next step

- Either, press **NextPt** to measure the next known point.
- Or, press **CALC.** to calculate the station position.

9.7.2 Measuring Information

Measurement sequences

The following measurement sequences are possible:

- Horizontal direction and vertical-angles only (resection)
- Distance and horizontal direction and vertical-angle
- Horizontal direction and vertical-angles to some point(s) and horizontal direction and vertical angles plus distance to other point(s).

Single face I, single face II, or dual face I and II measurements are always possible. No specific point sequence or specific face sequences are required.

Dual face measurements

When measuring the same target in both faces, the reflector height may not be changed when observing in the second face. Error checks are made for dual face measurements to ensure the same point is sighted with the other face.



- If a target point is measured several times in the same face, only the last valid measurement is used for computation.
 - For the calculation of the station position, measured target points can be re-measured, included in calculations, or excluded from calculations.
-

Measurements not included in computations

Target points with 0.000 height are discarded for height processing. If a target point has a valid height of 0.000 m, use 0.001 m to include it for height processing.

9.7.3 Computation Procedure

Description

The measuring procedure automatically determines the method of evaluation, for example resection or three point resection.

If more than the minimum required measurements are performed, the procedure uses a least squares adjustment to determine the 3D position and averages orientation and height measurements.

- The original averaged face I and face II measurements are used for the computation process.
 - All measurements are treated with the same accuracy, whether these are measured in single or dual face.
 - Easting and Northing are determined by the least squares method, which includes standard deviation and improvements for horizontal direction and horizontal distances.
 - The final height (H) is computed from averaged height differences based on the original measurements.
 - The horizontal direction is computed with the original averaged face I and face II measurements and the final computed plan position.
-

9.7.4 Resection Results

Access

Press **CALC.** from the **Sight target point** screen after at least two points and a distance have been measured.

STATION COORDINATES

This screen displays calculated station coordinates. The final computed results are Easting, Northing and Height coordinates of the present instrument station, including the instrument height. Standard deviations and residuals for accuracy assessments are provided.

STATION COORDINATES	
Stn :	S201
Inst. H:	1.400 m
Stn. E :	-0.000 m
Stn. N :	-0.000 m
Stn. Z :	0.000 m
[BACK] [RESID] [StdDev] [OK]	

RESID

To display residuals. Refer to "Target Residuals".

StdDev

To display the standard deviation of the coordinates and angle.



If the instrument height was set to 0.000 in the setup screen, then the station height refers to the height of the tilting axis.

Next step

Press **RESID** to display the target residuals.

Target Residuals

The **TARGET RESIDUALS** screen displays the computed residuals for the horizontal and vertical distances and the horizontal direction. Residual = Calculated value - Measured value.

Messages

The following are important messages or warnings that may appear.

Messages	Description
Selected point has no valid data!	This message occurs if the selected target point has no Easting or Northing coordinate.
Max 5 points supported!	5 points have already been measured and another point is selected. The system supports a maximum of 5 points.
Invalid data - no position computed!	The measurements may not allow final station coordinates (Eastings, Northings) to be computed.
Invalid data - no height computed!	Either the target height is invalid or insufficient measurements are available to compute a final station height.

Messages	Description
HA (I - II) > 0.9 deg, measure point again!	This error occurs if a point was measured in one face and the measurement in the other face differs by more than $180^\circ \pm 0.9^\circ$ for the horizontal angle.
VA (I - II) > 0.9 deg, measure point again!	This error occurs if a point was measured in one face and the measurement in the other face differs by more than $360^\circ - VA \pm 0.9^\circ$ for the vertical angle.
More points or distance required!	There is insufficient data measured to be able to compute a position. Either there are not enough points used or not enough distances measured.

Next step

Press **OK** to return to the **APPS** menu.

9.8 Set Out

Description

Set Out is an application used to place marks in the field at predetermined points. These predetermined points are the points to be staked. The points to be staked may already exist in a job on the instrument, or be manually entered.

The application can continuously display differences, between current position and desired set out position.

Set Out modes

Points can be staked using different modes: Polar mode, Orthogonal to station mode and Cartesian mode.

Polar Set Out mode

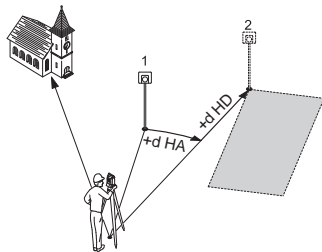

- 1 Current position
- 2 Point to be set out
- dHD Longitudinal offset: positive if point to be setout is further away.
- dHA Angle offset: positive if point to be setout is to the right of the actual direction.

Orthogonal to Station Set Out mode

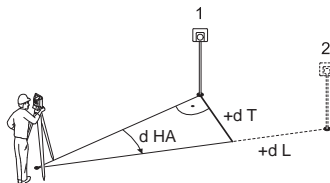

- 1 Current position
- 2 Point to be set out
- dL Longitudinal offset: positive if nominal point is further away.
- dT Transversal offset, perpendicular to line-of-sight: positive if nominal point is to the right of the measured point.
- dHA Angle offset: positive if nominal point is to the right of the actual direction.

Cartesian Set Out mode

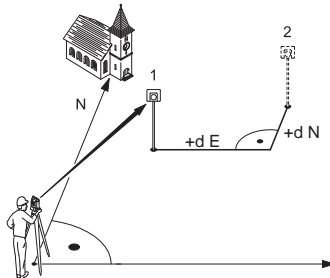

- 1 Current position
- 2 Point to be set out
- dE Easting offset between point to be set out and actual point.
- dN Northing offset between point to be set out and actual point.

Access

- 1) Select **Apps** from the **MAIN MENU**.
- 2) Select **Set Out** from the **APPS** menu.
- 3) Complete application pre-settings. Refer to "8 Applications - Getting Started".

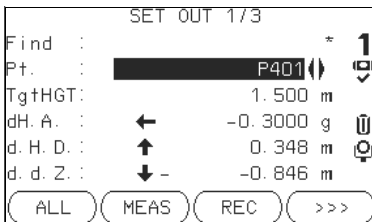
SET OUT

>>> MANUAL

To manually enter coordinates of a point.

>>> B&D

To enter the direction and horizontal distance to a set out point.



Press  to move through the pages. The bottom three measurement fields on the screen will change for the Polar, Orthogonal or Cartesian modes.

Field	Description
Find	Value for Point ID search. After entry, the firmware searches for matching points, and displays these in Pt. If a matching point doesn't exist the pointsearch screen opens.

Field	Description
d HA	Angle offset: Positive if set out point is to the right of the measured point.
d.H.D	Horizontal offset: Positive if set out point is further away than the measured point.
d.d.Z	Height offset: Positive if set out point is higher than the measured point.
dLength	Longitudinal offset: Positive if set out point is further away than the measured point.
dTrav.	Perpendicular offset: Positive if set out point is to the right of the measured point.
dE	Easting offset: Positive if set out point is to the right of the measured point.
dN	Northing offset: Positive if set out point is further away than the measured point
dZ	Height offset: Positive if set out point is higher than the measured point.

Next step

- Either, press **ALL** to record measurements for a set out point.
 - Or, press **ESC** to exit the application.
-

9.9 Area & Volume

Description

Area is an application used to compute online areas to a maximum of 50 points connected by straights. The target points have to be measured, selected from memory, or entered via the keypad in a clockwise direction. The calculated area is projected onto the horizontal plane (2D) or projected onto the sloped reference plane defined by three points (3D). Furthermore a volume with constant height can be calculated in relation to the area (2D/3D).

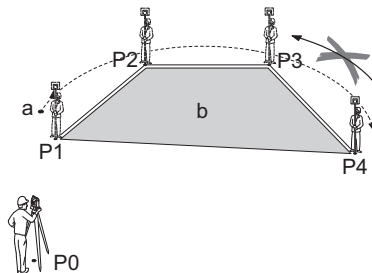

- P0 Instrument station
- P1 Start point
- P2-4 Target points
- a Perimeter, polygonal length from start point to the current measured point.
- b Calculated area always closed to the start point P1, projected onto the horizontal plane.

Access

- 1) Select **Apps** from the **MAIN MENU**.
- 2) Select **Area & Volume** from the **APPS** menu.
- 3) Complete application pre-settings. Refer to "8 Applications - Getting Started".

AREA & VOLUME

The graphic always shows the area projected onto the horizontal plane.

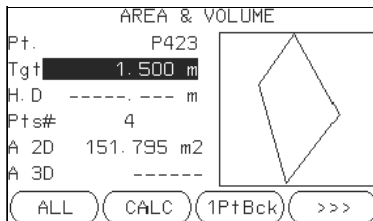
1PtBACK

To undo measurement or selection of the previous point.

CALC

To display and record additional results (perimeter, volume).

>>> VOLUME

To calculate a volume with constant height. The heights have to be entered or measured.

>>> Def. 3D

To define the sloped reference plane by selecting or measuring three points.



The 2D area is calculated and displayed once three points have been measured or selected. The 3D area is calculated once the sloped reference plane is defined by three points.

Graphical representation

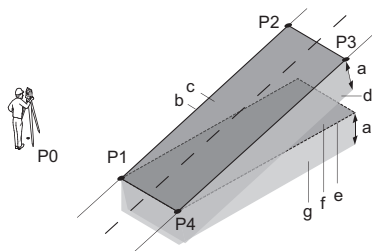

- P0 Instrument station
- P1 Target point which defines the sloped reference plane
- P2 Target point which defines the sloped reference plane
- P3 Target point which defines the sloped reference plane
- P4 Target point
- a Constant height

- b Perimeter (3D), polygonal length from the start point to the current measured point of the area (3D)
- c Area (3D), projected onto the sloped reference plane
- d Volume (3D) = $a \times c$
- e Perimeter (2D), polygonal length from the start point to the current measured point of the area (2D)
- f Area (2D), projected onto the horizontal plane
- g Volume (2D) = $f \times a$

Next step

Press **CALC** to calculate area and volume and proceed to the **Area & Volume Result** screens.

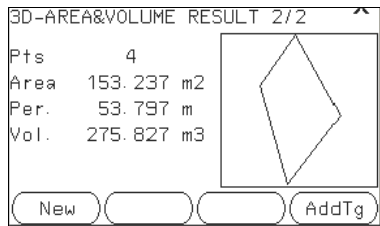
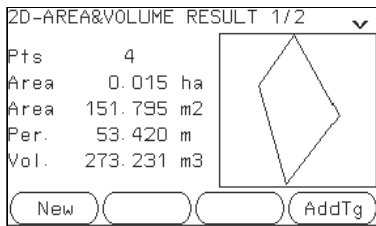
2D/3D-AREA & VOLUME RESULT

Perimeter and volume are updated if further area points are added.

Next step

- Either, press **New** to define a new area.
- Or, press **AddTg** to add a new target point to the existing area.
- Or, press **ESC** to exit the application.

9.10 Remote Elevation

Description

Remote Elevation is an application used to compute points directly above the base prism without a prism at the target point.

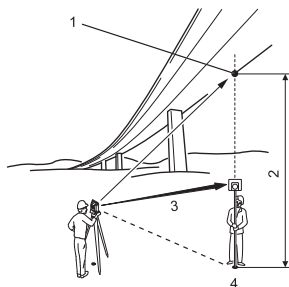

- 1 Remote point
- 2 Height difference
- 3 Slope distance
- 4 Base point

Access

- 1) Select **Apps** from the **MAIN MENU**.
- 2) Select **Remote Elevation** from the **APPS** menu.
- 3) Complete application pre-settings. Refer to "8 Applications - Getting Started".

Remote elevation measurement

Measure to the base point or press $\triangleright \triangleright \triangleright$ **Tgt.H=?** to determine an unknown reflector height.

Next step

After measuring, the **REMOTE ELEVATION** screen appears.

REMOTE ELEVATION - Aim at remote point

Aim the instrument at the inaccessible remote point.

Field	Description
hDIST	Height difference between the base point and the remote point.
Z	Height of the remote point.
d.d.Z	Calculated difference in Height between the base point and the remote point.

Next step

- Either, press **OK** to save the measurement of the remote point.
- Or, press **BACK** to enter and measure a new base point.
- Or, press **ESC** to exit the application.

9.11 Construction

9.11.1 Starting Construction

Description

Construction is an application used to define a construction site by combining set-up of the instrument along a construction line, measuring and setting out points in relation to the line.

Access

- 1) Select **Apps** from the **MAIN MENU**.
 - 2) Select **Construction** from the **APPS** menu.
 - 3) Select **Set EDM**: to set the EDM settings. Refer to "4.2 EDM Settings".
 - 4) Select:
 - **New line** - To define a new construction site, or
 - **Continue with line** - To continue with a previous construction site (skips set-up).
-



If coordinates were entered by **COORD** and measured to known points, a plausibility check displays the calculated line length, the actual length and the difference.

Next step

Measure to the line start and end points and the **LAY-OUT** screen appears.

9.11.2 Layout

Description

Search or enter points for setting out relative to the defined construction line. The on-screen graphics show the position of the prism relative to the set out point. Below the graphic, the exact values are displayed, combined with arrows to show the direction for setting out the point.



- Be aware that the line start point and the line end point are measured in the previous coordinate system. When setting out these points they appear in the old system and appear as shifted.
 - During use of the application the previous orientation and station parameters will be replaced by the new calculated ones. The line start point will be set to $E=0$, $N=0$.
 - The height of the line start point is always used as the reference height!
-

Access

- Either, select **New line** from the Construction pre-settings screen and measure start and end points of the line.
 - Or, select **Continue with line** from the Construction pre-settings screen.
-

LAY-OUT

The graphics are scaled to give a better overview. Therefore it is possible that the set out point moves in the graphic.

LAY-OUT			
Pt. :	P404	x	
tg.:	1.500 m	⊗	
dLi	-1.280 m	↑	0.191 m
dOf	31.329 m	←	0.081 m
d HG	-6.491 m	↑	1.599 m
MEAS		REC	
AsBLT		>>>	

AsBLT

To switch to AsBuilt mode to check points relative to the construction line.

>>> **Shift**

To enter values for shifting the line.

Field	Description
dLi	Longitudinal offset: Positive if target point is further away than the measured point.
dOf	Perpendicular offset: Positive if target point is to the right of the measured point.
d HG	Height offset: Positive if target point is higher than the measured point.

Next step

- Either, press **AsBLT** to check point locations relative to a construction line.
- Or, press >>> **Shift** to enter offset values for shifting the construction line.

9.11.3 As Built Check

Description

The As built screen displays the Line, Offset and d.d.Z of a measured point in relation to the construction line. The on-screen graphics show the position of the measured point relative to the construction line.



The height of the line start point is always used as the reference height!

Access

Press **AsBLT** from the **LAY OUT** screen.

AS-BUILT CHECK

The graphics are scaled to give a better overview. Therefore it is possible that the station point moves in the graphics.

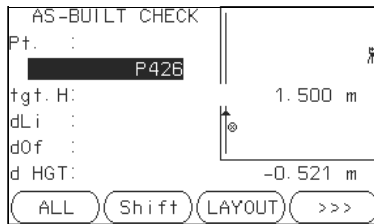

LAYOUT

To switch to Layout mode to set out points.

Shift

To enter values for shifting the line.

Field	Description
dLi	Longitudinal offset: Positive if measured point is further along the construction line from the start point.
dOf	Perpendicular offset: Positive if measured point is to the right of the construction line.
d HGT	Calculated difference in height: Positive if measured point is higher than the construction line start point height.

10 Data Management

10.1 Data Management

Access

Select **Data** from the **MAIN MENU**.

DATA MANAGEMENT

The Data Management menu contains all functions for entering, editing, checking and deleting data in the field.

DATA MANAGEMENT 1/2		
F1	Job	(1)
F2	Known Points	(2)
F3	Observations	(3)
F4	Code Library	(4)
<div style="display: flex; justify-content: space-around; margin-top: 10px;"> F1 F2 F3 F4 </div>		

F1-F4

To select menu item.

Menu item	Description
Job	To view, create and delete jobs. Jobs are a summary of data of different types, for example, known points, observations or codes. The job definition consists of the job name and user. The system generates time and date at the time of creation.

Menu item	Description
Known points	To view, create, edit and delete known points. Valid fixed points contain at least the point ID and the coordinates E, N or H.
Observations	To view and delete observation data. Observation data available in the internal memory can be searched for via a specific point search, or by viewing all points within a job.
Code Library	To view, create, edit and delete codes. To each code a description and a maximum of 8 attributes with up to 16 characters each can be assigned.
Formats	To view and delete data format files.
Erase Job Memory	To delete individual jobs, known points and measurements of a specific job or all jobs in the memory.  Deleting the memory cannot be undone. After confirming the message all data is permanently deleted.
Memory Info	Displays job specific memory information such as the number of stored stations and known points within a job, the number of recorded data blocks, for example measured points, or codes within a job, and the memory space occupied.

Menu item	Description
USB-Explorer	To view, delete, rename and create folders and files stored on the USB memory stick. Only available for Zoom 30 instruments. Refer to "10.4 Working with a USB Memory Stick" and "Appendix B Directory Structure".

Next step

- Either, select a menu option using **F1 - F4**.
 - Or, press **ESC** to return to the **MAIN MENU**.
-

10.2 Exporting Data

Description

Job data can be exported from the internal memory of the instrument. Data can be exported via:

The RS232 serial interface

A receiver, such as a laptop, is connected to the RS232 port. The receiver requires Zoom or another third party software.



If the receiver is too slow in processing data the data could be lost. With this type of data transfer the instrument is not informed about the performance of the receiver (no protocol). Therefore the success of this type of transfer is not checked.

A USB memory stick

For Zoom 30 instruments. A USB memory stick can be inserted and removed from the USB host port. No additional software is required for the transfer.

Access

- 1) Select **Transfer** from the **MAIN MENU**.
 - 2) Select **Export Data**.
-

DATA EXPORT

DATA EXPORT

To USB-Stick

Data Type Observations

Select Job J101

SEARCH

To search for jobs within the internal memory.

DISPL.

To list all jobs within the internal memory.

Field	Description
To	USB memory stick or RS232 serial interface.
Data Type	Data type to be transferred. Observations, Known Points or Obs. & Known points.
Select Job	Displays the selected job file.

Export data step-by-step

- 1) Press **OK** in the **DATA EXPORT** screen after selecting the export details.
- 2) Select the data format and press **OK** or **SEND**.



The **ASCII** data format is only available for data exports to a USB memory stick, not via the RS232 serial interface.



All jobs will be stored in the backup folder created on the USB memory stick. The job data will be stored as individual database files for each job, which can then be imported again. Refer to "10.3 Importing Data".

Exportable job data formats

Job data can be exported from a job in a variety of file types. A format can be defined in GGO Format Manager. Refer to the online help of GGO for information on creating format files.

RS232 example job data output

Within the **Data Type** setting **Observations**, a data set could be shown as follows:

11...+00000D19	21..022+16641826	22..022+09635023
31..00+00006649	58..16+00000344	81..00+00003342
82..00-00005736	83..00+00000091	87..10+00001700

GSI-IDs			GSI-IDs continued		
11	△	Pt	41-49	△	Codes and attributes
21	△	Horizontal direction	51	△	ppm [mm]
22	△	Vertical angle	58	△	Prism constants
25	△	Orientation	81-83	△	(E, N, H) Target point
31	△	Slope distance	84-86	△	(E, N, H) Station point
32	△	Horizontal distance	87	△	Reflector height

GSI-IDs			GSI-IDs continued		
33	△	Height difference	88	△	Instrument height

10.3 Importing Data

Description

For Zoom 30 instruments, data can be imported to the internal memory of the instrument via a USB memory stick.

Importable data formats

When importing data, the instrument automatically stores the file in a directory folder based on the file extension. The following data formats can be imported:

Data Type	File extension	Recognised as
GSI	.gsi	Known points
Format	.fmt	Format file
Codelist	.cls	Codelist file

Access

- 1) Select **Transfer** from the **MAIN MENU**.
 - 2) Select **Import Data**.
-

DATA IMPORT

DATA IMPORT

From: USB-Stick

To : Instrument

File: Single File

Field	Description
From	USB-Stick
To	Instrument
File	Single File

Import data step-by-step

- 1) Press **OK** in the **DATA IMPORT** screen to proceed to the USB memory stick file directory.
 - 2) Select the file on the USB memory stick to be imported and press **OK**.
 - 3) Define the Job name for the imported file, and, if requested, the file definition and layers, and press **OK** to import. If a Job with the same name already exists in the internal memory, a message will appear with the options to overwrite the existing job or rename the job for the file being imported.
 - 4) A message will display once the file has been successfully imported.
-

10.4 Working with a USB Memory Stick

Insert a USB memory stick step-by-step

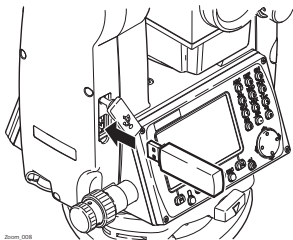

Lift the lid covering the USB host port on the Zoom 30 instrument.

Insert the USB memory stick into the USB host port.



Always return to the **MAIN MENU** before removing the USB memory stick.



GeoMax cannot be held responsible for data loss or any other error that may occur when using a USB memory stick.



- Keep the USB memory stick dry.
- Use it only within the specified temperature range.
- Protect the USB memory stick from direct impacts.

Failure to follow these instructions could result in data loss and/or permanent damage to the USB memory stick.

10.5 Working with Bluetooth

Description

Zoom 30 instruments can communicate with external devices via a Bluetooth connection. The instrument Bluetooth is a slave only. The Bluetooth of the external device will be the master, and therefore will control the connection and any data transfer.

Establishing a connection step-by-step

- 1) On the instrument ensure that the communication parameters are set to **Bluetooth** and **On**. Refer to "4.3 Communication Settings".
- 2) Activate Bluetooth on the external device. The steps required depend on the Bluetooth driver and other device specific configurations. Refer to the device user manual for information on how to configure and search for a Bluetooth connection.
The instrument will appear on the external device.
- 3) Some devices ask for the identification number of the Bluetooth. The default number for a Zoom Bluetooth is 0000. This can be changed by:
 - Select **Settings** from the **MAIN MENU**.
 - Select **Comm.** from the **SETTINGS** menu.
 - Press **BTCode** from the **COMMUNICATION SETTINGS** screen.
 - Enter a new Bluetooth code in **BT-Code:**
 - Press **OK** to confirm the new Bluetooth code.

- 4 When the external Bluetooth device has located the instrument for the first time, a message will display on the instrument stating the name of the external device and requesting confirmation that connection to this device should be allowed.
 - Press **YES** to allow, or
 - Press **NO** to disallow this connection
 - 5 The instrument Bluetooth sends out the instrument name and serial number to the external Bluetooth device.
 - 6 All further steps must be made in accordance to the user manual of the external device.
-

Transferring data via Bluetooth

Using GGO Data Exchange Manager, data files can be transferred from the instrument to a local folder via the Bluetooth connection. The transfer is made through the serial port configured on the computer as the Bluetooth Serial Port, however, for faster data transfer speeds we recommend using the USB or RS232 connections.

For more information about GGO Data Exchange Manager refer to the comprehensive online help.

For transferring data using other external devices or software programs, refer to the user manual of the device or software. The Zoom 30 Bluetooth does not establish or manage the data transfer.

10.6 Working with GeoMax Geo Office and GGO Tools

Description

The program package GGO is used for the data exchange between the instrument and a computer. It contains several auxiliary programs in order to support the instrument.

Installation on a computer

The installation program can be found on the CD-ROM supplied. Insert the CD and follow the on-screen instructions. Please note that GGO can only be installed on computers with MS Windows 2000, XP and Vista operating systems.



For more information about GGO refer to the comprehensive online help.

11 Calibration

11.1 Overview

Description

GeoMax instruments are manufactured, assembled and adjusted to a high quality. Quick temperature changes, shock or stress can cause deviations and decrease the instrument accuracy. It is therefore recommended to calibrate the instrument from time to time. This can be done in the field by running through specific measurement procedures. The procedures are guided and have to be followed carefully and precisely as described in the following chapters. Some other instrument errors and mechanical parts can be adjusted mechanically.

Electronic calibration

The following instrument errors can be checked and calibrated electronically:

- Horizontal collimation error, also called line-of-sight error.
 - Vertical index error, and simultaneously the electronic level.
-



For determining these errors, it is necessary to measure in both faces, but the procedure can be started in any face.

Mechanical calibration



The following instrument parts can be calibrated mechanically:

- Circular level on the instrument and tribrach.
 - Laser plummet.
 - Screws on the tripod.
-

During the manufacturing process, the instrument errors are carefully determined and set to zero. As mentioned, these errors can change and it is highly recommended to redetermine them in the following situations:

- Before the instrument is used for the first time.
 - Before every high precision survey.
 - After rough or long periods of transport.
 - After long periods of work or storage.
 - If the temperature difference between current environment and the temperature at the last calibration is more than 10°C (18°F).
-

11.2 Preparation



Before determining the instrument errors, level-up the instrument using the electronic level. The **Level & Plummet** is the first screen to appear after turning on the instrument.

The tribrach, the tripod and the ground should be very stable and secure from vibrations or other disturbances.



The instrument should be protected from direct sunlight in order to avoid thermal expansion on one side only.



Before starting to work, the instrument has to become acclimatised to the ambient temperature. Approximately two minutes per °C of temperature difference from storage to working environment, but at least 15 min, should be taken into account.

11.3 Calibrating Line-of-Sight and Vertical Index Error

Line-of-sight error

The line-of-sight error, or horizontal collimation error is the deviation from the perpendicular between the tilting axis and the line of sight. The effect of the line-of-sight error to the horizontal direction increases with the vertical angle.

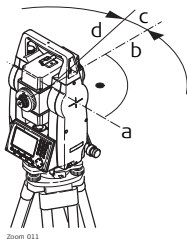

- a) Tilting axis
- b) Line perpendicular to tilting axis
- c) Horizontal collimation, or line-of-sight, error
- d) Line-of-sight

Vertical index error

The vertical circle should read exactly 90° (100 gon) when the line of sight is horizontal. Any deviation from this figure is termed vertical index error. This is a constant error that affects all vertical angle readings.

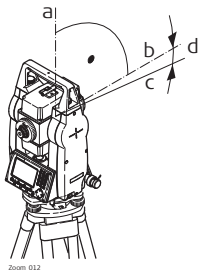

- a) Mechanical vertical axis of the instrument, also called standing axis
- b) Axis perpendicular to the vertical axis. True 90°
- c) Vertical angle is reading 90°
- d) Vertical index error



By determining the vertical index error the electronic level is adjusted automatically

Access

- 1) Select **Tools** from the **MAIN MENU**.
- 2) Select **Calibr.** from the **TOOLS MENU**.
 - Select:
 - **HA-collimation**, or
 - **Vertical Index**.



The procedures and conditions required to correct line-of-sight and vertical index errors are the same, therefore the procedure will only be described once.

Calibration step-by-step

- 1) Level the instrument with the electronic level. Refer to "3 Operation"- "Level up with the electronic level step-by-step".

2

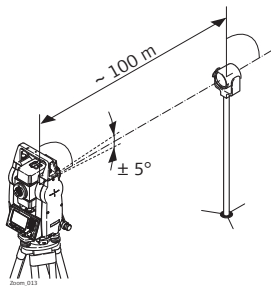

Aim at a point approximately 100 m from the instrument which is within 5° of the horizontal.

- 3 Press **REC** to measure to the target point.

4

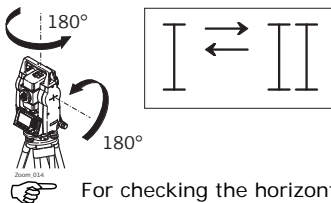

Change face and aim at the target point again

For checking the horizontal aim, the difference in HA and VA are displayed.

- 5 Press **REC** to measure to the target point.
 -  The old and new calculated values are displayed.
- 6 Either:
 - Press **OK** to save the new calibration data, or
 - Press **ESC** to exit without saving the new calibration data.

Messages

The following are important messages or warnings that may appear.

Messages	Description
VA-angle not suitable for adjustment !	The vertical angle deviates from the required horizontal / line-of-sight, or in face II the vertical angle deviates by more than 5° from the target point. Aim at the target point with an accuracy of min. 5°. Confirmation of the message required.
Results out of tolerance. Previous values retained !	Computed values out of tolerance. The previous values are retained and measurements should be repeated. Confirmation of the message required.
HA-angle not suitable for adjustment !	Horizontal angle in face II deviates by more than 5° from the target point. Aim on the target point with an accuracy of min. 5°. Confirmation of the message required.

Messages	Description
Measurement Error. Try again.	Measurement error appears when, for example, there is an unstable set up. Repeat the process. Confirmation of the message required.
Time limit exceeded ! Please repeat adjustment !	Time difference between measurements for results storage exceeds 15 minutes. Repeat the process. Confirmation of the message required.

11.4 Calibrating the Circular Level of the Instrument and Tribrach

Calibrate the circular level step-by-step

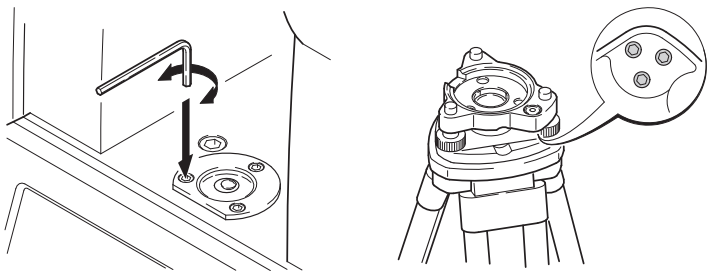

- 1 Place and secure the tribrach onto the tripod, and then secure the instrument onto the tribrach.
- 2 Using the tribrach footscrews, level the instrument with the electronic level. To activate the electronic level, turn on the instrument, and, if tilt correction is set to 1- or 2-axis, the **Level & Plummet** screen appears automatically. Alternatively, press **FNC** from within any application and select **Level & Plummet**.

- 3 The bubbles of the instrument and tribrach levels must be centered. If one or both circular levels are not centered, adjust as follows.

Instrument: If the bubble extends beyond the circle, use the Allen key supplied to center it with the adjustment screws.

Tribrach: If the bubble extends beyond the circle, adjust it using the adjustment pin in conjunction with the adjustment screws. Turn the adjustment screws:

- To the left: and the bubble approaches the screw.
- To the right: and the bubble goes away from the screw.

- 4 Repeat step 3 on the instrument and tribrach until both circular levels are centered and no further adjustments are necessary.



After the calibration, no adjustment screw should be loose.

11.5 Inspecting the Laser Plummet of the Instrument



The laser plummet is integrated into the vertical axis of the instrument. Under normal conditions of use, the laser plummet does not need adjusting. If an adjustment is necessary due to external influences, the instrument has to be returned to a GeoMax service department.

Inspect the laser plummet step-by-step

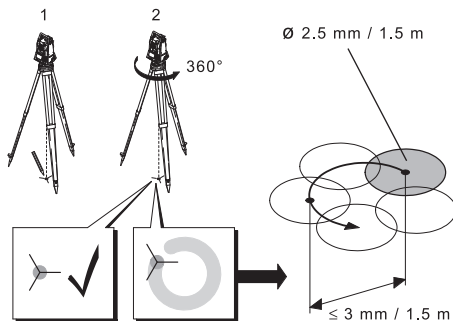

- 1) Set up the instrument on the tripod approximately 1.5 m above the ground and level up.
- 2) To activate the laser plummet, turn on the instrument, and, if tilt correction is set to 1- or 2-axis, the laser plummet will be activated automatically, and

the **Level & Plummet** screen appears. Otherwise, press **FNC** from within any application and select **Level & Plummet**.



Inspection of the laser plummet should be carried out on a bright, smooth and horizontal surface, such as a sheet of paper.

- 3 Mark the center of the red laser dot on the ground.
- 4 Turn the instrument slowly through 360° , carefully observing the movement of the red laser dot.



The maximum diameter of the circular movement described by the center of the laser dot should not exceed 3 mm at a height of 1.5 m.

- 5 If the center of the laser dot makes a clearly circular movement, or moves more than 3 mm away from the point which was first marked, an adjustment may be required. Call your nearest GeoMax service department. Depending on brightness and surface type, the size of the laser dot can vary. At a height of 1.5 m an average diameter of 2.5 mm is estimated.
-

11.6 Servicing the Tripod

Service the tripod step-by-step

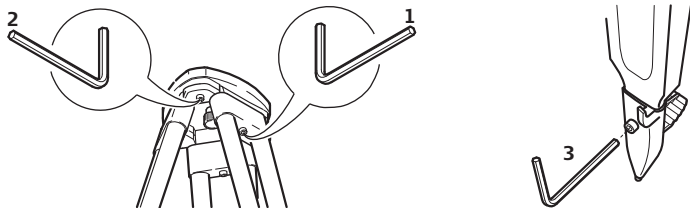

The connections between metal and timber components must always be firm and tight.

- 1) Tighten the leg cap screws moderately with the allen key supplied.
- 2) Tighten the articulated joints on the tripod head just enough to keep the tripod legs open when lifting the tripod off the ground.
- 3) Tighten the screws of the tripod legs.

12 Care and Transport

12.1 Transport

Transport in the field

When transporting the equipment in the field, always make sure that you

- either carry the product in its original transport container,
- or carry the tripod with its legs splayed across your shoulder, keeping the attached product upright.

Transport in a road vehicle

Never carry the product loose in a road vehicle, as it can be affected by shock and vibration. Always carry the product in its transport container and secure it.

Shipping

When transporting the product by rail, air or sea, always use the complete original GeoMax packaging, transport container and cardboard box, or its equivalent, to protect against shock and vibration.

Shipping, transport of batteries

When transporting or shipping batteries, the person in charge of the product must ensure that the applicable national and international rules and regulations are observed. Before transportation or shipping, contact your local passenger or freight transport company.

Field adjustment

After transport inspect the field adjustment parameters given in this user manual before using the product.

12.2 Storage

Product

Respect the temperature limits when storing the equipment, particularly in summer if the equipment is inside a vehicle. Refer to "14 Technical Data" for information about temperature limits.

Field adjustment

After long periods of storage inspect the field adjustment parameters given in this user manual before using the product.

Li-Ion batteries

- Refer to "14 Technical Data" for information about storage temperature range.
 - At the recommended storage temperature range, batteries containing a 10% to 50% charge can be stored for up to one year. After this storage period the batteries must be recharged.
 - Remove batteries from the product and the charger before storing.
 - After storage recharge batteries before using.
 - Protect batteries from damp and wetness. Wet or damp batteries must be dried before storing or use.
 - A storage temperature range of -20°C to +30°C/-4°F to 86°F in a dry environment is recommended to minimise self-discharging of the battery.
-

12.3 Cleaning and Drying

Objective, eyepiece and reflectors

- Blow dust off lenses and prisms.
 - Never touch the glass with your fingers.
 - Use only a clean, soft, lint-free cloth for cleaning. If necessary, moisten the cloth with water or pure alcohol. Do not use other liquids; these may attack the polymer components.
-

Fogging of prisms

Prisms that are cooler than the ambient temperature tend to fog. It is not enough simply to wipe them. Keep them for some time inside your jacket or in the vehicle to allow them to adjust to the ambient temperature.

Damp products

Dry the product, the transport container, the foam inserts and the accessories at a temperature not greater than 40°C /104°F and clean them. Do not repack until everything is completely dry. Always close the transport container when using in the field.

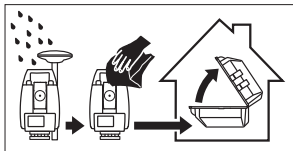

Cables and plugs

Keep plugs clean and dry. Blow away any dirt lodged in the plugs of the connecting cables.

13 Safety Directions

13.1 General

Description

The following directions enable the person responsible for the product, and the person who actually uses the equipment, to anticipate and avoid operational hazards.

The person responsible for the product must ensure that all users understand these directions and adhere to them.

13.2 Intended Use

Permitted use

- Measuring horizontal and vertical angles.
 - Measuring distances.
 - Recording measurements.
 - Visualizing the aiming direction and vertical axis.
 - Data communication with external appliances.
 - Computing by means of software.
-

Adverse use

- Use of the product without instruction.
- Use outside of the intended limits.
- Disabling safety systems.
- Removal of hazard notices.
- Opening the product using tools, for example screwdriver, unless this is specifically permitted for certain functions.
- Modification or conversion of the product.
- Use after misappropriation.
- Use of products with obviously recognisable damages or defects.
- Use with accessories from other manufacturers without the prior explicit approval of GeoMax.
- Aiming directly into the sun.

- Inadequate safeguards at the working site, for example when measuring on roads.
- Deliberate dazzling of third parties.
- Controlling of machines, moving objects or similar monitoring application without additional control- and safety installations.



Warning

Adverse use can lead to injury, malfunction and damage.

It is the task of the person responsible for the equipment to inform the user about hazards and how to counteract them. The product is not to be operated until the user has been instructed on how to work with it.

13.3 Limits of Use

Environment

Suitable for use in an atmosphere appropriate for permanent human habitation: not suitable for use in aggressive or explosive environments.



Danger

Local safety authorities and safety experts must be contacted before working in hazardous areas, or close to electrical installations or similar situations by the person in charge of the product.

13.4 Responsibilities

Manufacturer of the product

GeoMax AG, CH-9443 Widnau, hereinafter referred to as GeoMax, is responsible for supplying the product, including the user manual and original accessories, in a safe condition.

Manufacturers of non GeoMax accessories

The manufacturers of non GeoMax accessories for the product are responsible for developing, implementing and communicating safety concepts for their products, and are also responsible for the effectiveness of those safety concepts in combination with the GeoMax product.

Person in charge of the product

The person in charge of the product has the following duties:

- To understand the safety instructions on the product and the instructions in the user manual.
 - To be familiar with local regulations relating to safety and accident prevention.
 - To inform GeoMax immediately if the product and the application becomes unsafe.
 - To ensure that the national laws, regulations and conditions for the operation of radio transmitters are respected.
-

**Warning**

The person responsible for the product must ensure that it is used in accordance with the instructions. This person is also accountable for the training and the deployment of personnel who use the product and for the safety of the equipment in use.

13.5 Hazards of Use



Warning

The absence of instruction, or the inadequate imparting of instruction, can lead to incorrect or adverse use, and can cause accidents with far-reaching human, material, financial and environmental consequences.

Precautions:

All users must follow the safety directions given by the manufacturer and the directions of the person responsible for the product.



Caution

Watch out for erroneous measurement results if the product has been dropped or has been misused, modified, stored for long periods or transported.

Precautions:

Periodically carry out test measurements and perform the field adjustments indicated in the user manual, particularly after the product has been subjected to abnormal use and before and after important measurements.



Danger

Because of the risk of electrocution, it is dangerous to use poles and extensions in the vicinity of electrical installations such as power cables or electrical railways.

Precautions:

Keep at a safe distance from electrical installations. If it is essential to work in this environment, first contact the safety authorities responsible for the electrical installations and follow their instructions.

 **Warning**

If the product is used with accessories, for example masts, staffs, poles, you may increase the risk of being struck by lightning.

Precautions:

Do not use the product in a thunderstorm.

 **Caution**

Be careful when pointing the product towards the sun, because the telescope functions as a magnifying glass and can injure your eyes and/or cause damage inside the product.

Precautions:

Do not point the product directly at the sun.

 **Warning**

During dynamic applications, for example stakeout procedures there is a danger of accidents occurring if the user does not pay attention to the environmental conditions around, for example obstacles, excavations or traffic.

Precautions:

The person responsible for the product must make all users fully aware of the existing dangers.

 **Warning**

Inadequate securing of the working site can lead to dangerous situations, for example in traffic, on building sites, and at industrial installations.

Precautions:

Always ensure that the working site is adequately secured. Adhere to the regulations governing safety and accident prevention and road traffic.

 **Warning**

If computers intended for use indoors are used in the field there is a danger of electric shock.

Precautions:

Adhere to the instructions given by the computer manufacturer regarding field use with GeoMax products.

 **Caution**

If the accessories used with the product are not properly secured and the product is subjected to mechanical shock, for example blows or falling, the product may be damaged or people can sustain injury.

Precautions:

When setting-up the product, make sure that the accessories are correctly adapted, fitted, secured, and locked in position.

Avoid subjecting the product to mechanical stress.

Caution

During the transport, shipping or disposal of batteries it is possible for inappropriate mechanical influences to constitute a fire hazard.

Precautions:

Before shipping the product or disposing of it, discharge the batteries by running the product until they are flat.

When transporting or shipping batteries, the person in charge of the product must ensure that the applicable national and international rules and regulations are observed. Before transportation or shipping contact your local passenger or freight transport company.

Warning

Using a battery charger not recommended by GeoMax can destroy the batteries. This can cause fire or explosions.

Precautions:

Only use chargers recommended by GeoMax to charge the batteries.

Warning

High mechanical stress, high ambient temperatures or immersion into fluids can cause leakage, fire or explosions of the batteries.

Precautions:

Protect the batteries from mechanical influences and high ambient temperatures. Do not drop or immerse batteries into fluids.

Warning

If battery terminals come in contact with jewellery, keys, metallised paper or other metals, short circuited battery terminals can overheat and cause injury or fire, for example by storing or transporting in pockets.

Precautions:

Make sure that the battery terminals do not come into contact with metallic objects.

 **Warning**

Batteries not recommended by GeoMax may be damaged if charged or discharged. They may burn and explode.

Precautions:

Only charge and discharge batteries recommended by GeoMax.

 **Warning**

If the product is improperly disposed of, the following can happen:

- If polymer parts are burnt, poisonous gases are produced which may impair health.
- If batteries are damaged or are heated strongly, they can explode and cause poisoning, burning, corrosion or environmental contamination.
- By disposing of the product irresponsibly you may enable unauthorised persons to use it in contravention of the regulations, exposing themselves and third parties to the risk of severe injury and rendering the environment liable to contamination.
- Improper disposal of silicone oil may cause environmental contamination.

Precautions:

The product must not be disposed with household waste.

Dispose of the product appropriately in accordance with the national regulations in force in your country.

Always prevent access to the product by unauthorised personnel.

Product specific treatment and waste management information is available from GeoMax AG.

Warning

Only GeoMax authorised service workshops are entitled to repair these products.

13.6 Laser Classification

13.6.1 General

General

The following directions (in accordance with the state of the art - international standard IEC 60825-1 (2007-03) and IEC TR 60825-14 (2004-02)) provide instruction and training information to the person responsible for the product and the person who actually uses the equipment, to anticipate and avoid operational hazards.

The person responsible for the product must ensure that all users understand these directions and adhere to them.



Products classified as laser class 1, class 2 and class 3R do not require:

- laser safety officer involvement,
- protective clothes and eyewear,
- special warning signs in the laser working area

if used and operated as defined in this user manual due to the low eye hazard level.



Products classified as laser class 2 or class 3R may cause dazzle, flash-blindness and afterimages, particularly under low ambient light conditions.

13.6.2 Distancer, Measurements with Reflectors

General

The EDM module built into this product produces a visible laser beam which emerges from the telescope objective.

The laser product described in this section, is classified as laser class 1 in accordance with:



- IEC 60825-1 (2007-03): "Safety of laser products".
- EN 60825-1 (2007-10): "Safety of laser products".

Class 1 laser products are safe under reasonably foreseeable conditions of operation and are not harmful to the eyes provided that the products are used and maintained in accordance with this user manual.

Description	Value
Maximum average radiant power	0.33 mW
Pulse duration	800 ps
Pulse repetition frequency	100 MHz - 150 MHz
Wavelength	650 nm - 690 nm

Labelling

.....
.....
.....
.....
.....



Complies with FDA performance standards for laser products except for deviations pursuant to Laser Notice No. 50, dated June 24, 2007.
This device complies with part 15 of the FCC Rules. Operation is subject to the following two conditions:
(1) This device may not cause harmful interference, and
(2) this device must accept any interference received, including interference that may cause undesired operation.

Class 1 Laser Product
according to IEC 60825-1
(2007 - 03)

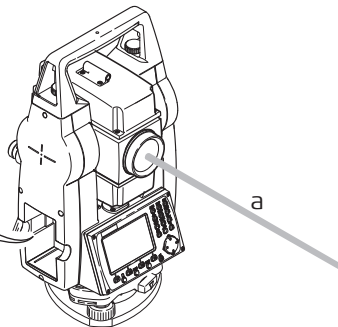

Zoom_017

a) Laser beam

13.6.3 Distancer, Measurements without Reflectors (Reflectorless mode)

General

The EDM module built into the product produces a visible laser beam which emerges from the telescope objective.

The laser product described in this section is classified as laser class 3R in accordance with:

- IEC 60825-1 (2007-03): "Safety of laser products".
- EN 60825-1 (2007-10): "Safety of laser products".

Class 3R laser products:

Direct intrabeam viewing may be hazardous (low-level eye hazard), in particular for deliberate ocular exposure. The risk of injury for laser class 3R products is limited because of:

- unintentional exposure would rarely reflect worst case conditions of (e.g.) beam alignment with the pupil, worst case accommodation,
- inherent safety margin in the maximum permissible exposure to laser radiation (MPE), natural aversion behaviour for exposure to bright light for the case of visible radiation.

Description	Value (A2/A4/A6)
Maximum average radiant power	5.00 mW
Pulse duration	800 ps
Pulse repetition frequency	100 MHz - 150 MHz
Wavelength	650 nm - 690 nm
Beam divergence	0.2 mrad x 0.3 mrad
NOHD (Nominal Ocular Hazard Distance) @ 0.25 s	80 m / 262 ft



Warning

From a safety perspective class 3R laser products should be treated as potentially hazardous.

Precautions:

Prevent direct eye exposure to the beam. Do not direct the beam at other people.



Warning

Potential hazards are not only related to direct beams but also to reflected beams aimed at reflecting surfaces such as prisms, windows, mirrors, metallic surfaces etc.

Precautions:

Do not aim at areas that are essentially reflective, such as a mirror, or which could emit unwanted reflections.

Do not look through or beside the optical sight at prisms or reflecting objects when the laser is switched on, in laser pointer or distance measurement mode. Aiming at prisms is only permitted when looking through the telescope.

Labelling

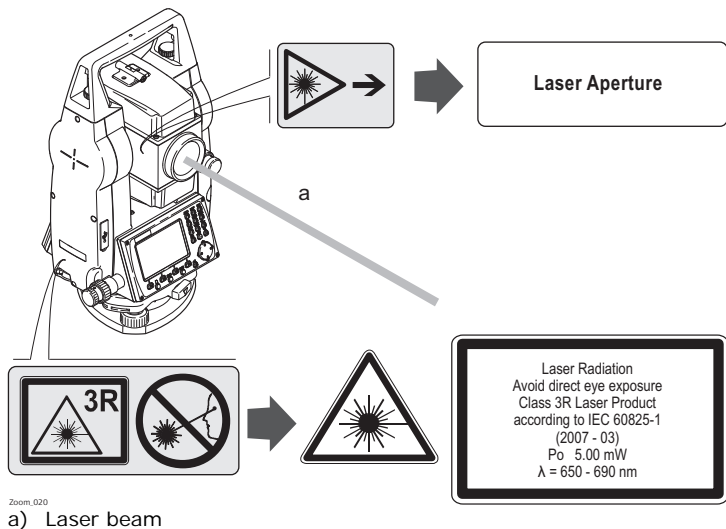

.....

.....

.....

.....

.....

.....



.....

.....

.....

.....

.....





Complies with FDA performance standards for laser products except for deviations pursuant to Laser Notice No. 50, dated June 24, 2007.

This device complies with part 15 of the FCC Rules. Operation is subject to the following two conditions:

(1) This device may not cause harmful interference, and

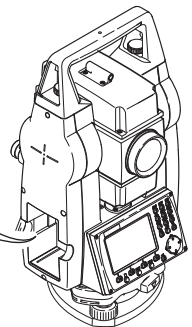
(2) this device must accept any interference received, including interference that may cause undesired operation.



13.6.4 Laser Plummet

General

The laser plummet built into the product produces a visible red laser beam which emerges from the bottom of the product.

The laser product described in this section, is classified as laser class 2 in accordance with:

- IEC 60825-1 (2007-03): "Safety of laser products".
- EN 60825-1 (2007-10): "Safety of laser products".

Class 2 laser products:

These products are safe for momentary exposures but can be hazardous for deliberate staring into the beam.

Description	Value
Maximum average radiant power	1.00 mW
Pulse duration	0-100%
Pulse repetition frequency	1 kHz
Wavelength	620 nm - 690 nm

Warning

From a safety perspective class 2 laser products are not inherently safe for the eyes.

Precautions:

Avoid staring into the beam or pointing the beam at other people.

Labelling

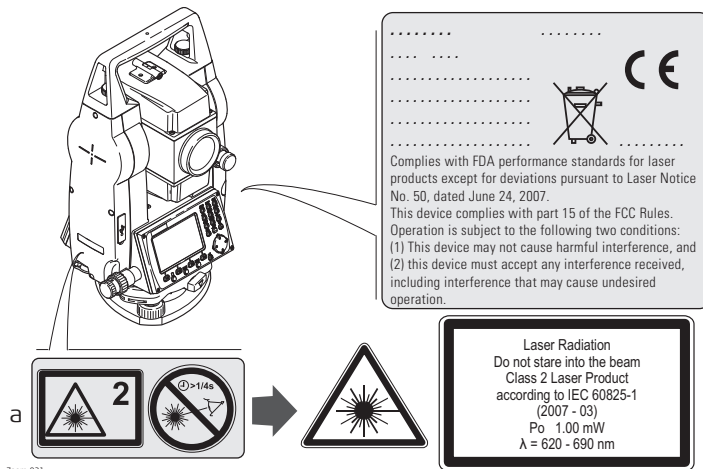

Zoom_021

a) Will be replaced by a Class 3R warning label if applicable

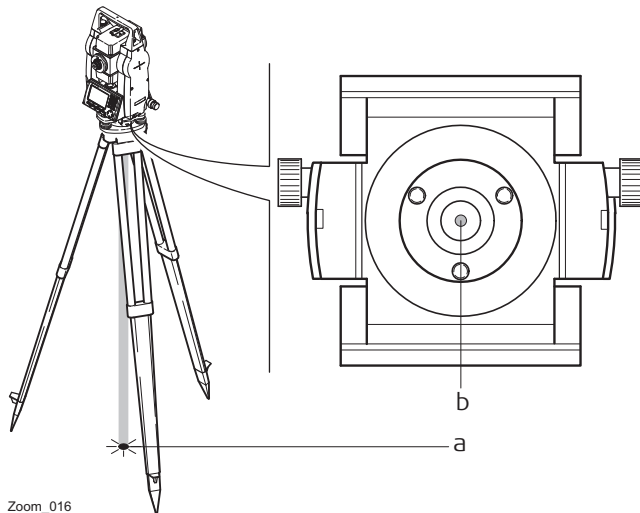

Zoom_016

- a) Laser beam
- b) Exit for laser beam

13.7 Electromagnetic Compatibility EMC

Description

The term Electromagnetic Compatibility is taken to mean the capability of the product to function smoothly in an environment where electromagnetic radiation and electrostatic discharges are present, and without causing electromagnetic disturbances to other equipment.



Warning

Electromagnetic radiation can cause disturbances in other equipment.

Although the product meets the strict regulations and standards which are in force in this respect, GeoMax cannot completely exclude the possibility that other equipment may be disturbed.



Caution

There is a risk that disturbances may be caused in other equipment if the product is used with accessories from other manufacturers, for example field computers, personal computers, two-way radios, non-standard cables or external batteries.

Precautions:

Use only the equipment and accessories recommended by GeoMax. When combined with the product, they meet the strict requirements stipulated by the guidelines and standards. When using computers and two-way radios, pay attention to the information about electromagnetic compatibility provided by the manufacturer.

 **Caution**

Disturbances caused by electromagnetic radiation can result in erroneous measurements.

Although the product meets the strict regulations and standards which are in force in this respect, GeoMax cannot completely exclude the possibility that the product may be disturbed by intense electromagnetic radiation, for example, near radio transmitters, two-way radios or diesel generators.

Precautions:

Check the plausibility of results obtained under these conditions.

 **Warning**

If the product is operated with connecting cables attached at only one of their two ends, for example external supply cables, interface cables, the permitted level of electromagnetic radiation may be exceeded and the correct functioning of other products may be impaired.

Precautions:

While the product is in use, connecting cables, for example product to external battery, product to computer, must be connected at both ends.

Bluetooth

Use of product with Bluetooth:

 **Warning**

Electromagnetic radiation can cause disturbances in other equipment, in installations, in medical devices, for example pacemakers or hearing aids and in aircraft. It can also affect humans and animals.

Precautions:

Although the product meets in combination with radio or digital cellular phone devices recommended by GeoMax the strict regulations and standards which are in force in this respect, GeoMax cannot completely exclude the possibility that other equipment may be disturbed or that humans or animals may be affected.

- Do not operate the product with radio or digital cellular phone devices in the vicinity of filling stations or chemical installations, or in other areas where an explosion hazard exists.
 - Do not operate the product with radio or digital cellular phone devices near to medical equipment.
 - Do not operate the product with radio or digital cellular phone devices in aircraft.
-

13.8 FCC Statement, Applicable in U.S.

Applicability

The greyed paragraph below is only applicable for Zoom 20 instruments.



Warning

This equipment has been tested and found to comply with the limits for a Class B digital device, pursuant to part 15 of the FCC rules.

These limits are designed to provide reasonable protection against harmful interference in a residential installation.

This equipment generates, uses and can radiate radio frequency energy and, if not installed and used in accordance with the instructions, may cause harmful interference to radio communications. However, there is no guarantee that interference will not occur in a particular installation.

If this equipment does cause harmful interference to radio or television reception, which can be determined by turning the equipment off and on, the user is encouraged to try to correct the interference by one or more of the following measures:



- Reorient or relocate the receiving antenna.
 - Increase the separation between the equipment and the receiver.
 - Connect the equipment into an outlet on a circuit different from that to which the receiver is connected.
 - Consult the dealer or an experienced radio/TV technician for help.
-

 **Warning**

Changes or modifications not expressly approved by GeoMax for compliance could void the user's authority to operate the equipment.

Labelling Zoom instrument

.....

 

.....

Complies with FDA performance standards for laser products except for deviations pursuant to Laser Notice No. 50, dated June 24, 2007.
 This device complies with part 15 of the FCC Rules.
 Operation is subject to the following two conditions:
 (1) This device may not cause harmful interference, and
 (2) this device must accept any interference received, including interference that may cause undesired operation.

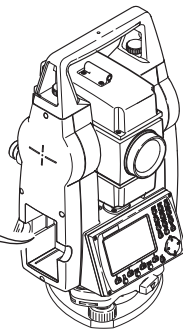

Labelling internal battery ZBA400

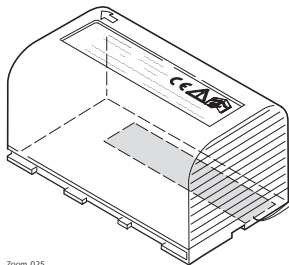

Zoom_025

This device complies with part 15 of the FCC Rules. Operation is subject to the following two conditions: (1) This device may not cause harmful interference, and (2) this device must accept any interference received, including interference that may cause undesired operation.

 US LISTED
ITE Accessory
E179078 . 70YL

14 Technical Data

14.1 Angle Measurement

Accuracy

Available angular accuracies	Standard deviation HA, VA, ISO 17123-3	Display resolution			
		["']	[°]	[mgon]	[mil]
2	0.6	1	0.0001	0.1	0.01
3	1.0	1	0.0001	0.1	0.01
5	1.5	1	0.0001	0.1	0.01
7	2	1	0.0001	0.1	0.01

Characteristics

Absolute, continuous, diametric. Updates each 0.1 to 0.3 s.

14.2 Distance Measurement with Reflectors

Range

Reflector	Range A		Range B		Range C	
	[m]	[ft]	[m]	[ft]	[m]	[ft]
Standard prism	1800	6000	3000	10000	3500	12000
3 prisms	2300	7500	4500	14700	5400	17700
Reflector foil 60 mm x 60 mm	150	500	250	800	250	800

Shortest measuring distance: 1.5 m

Atmospheric conditions

Range A: Strong haze, visibility 5 km; or strong sunlight, severe heat shimmer

Range B: Light haze, visibility about 20 km; or moderate sunlight, slight heat shimmer

Range C: Overcast, no haze, visibility about 40 km; no heat shimmer

Accuracy

Accuracy refers to measurements to standard reflectors.

EDM measuring mode	Standard deviation ISO 17123-4	Measurement time, typical [s]
IR-Default	2 mm + 2 ppm	2.4
IR-Quick	5 mm + 2 ppm	0.8
IR-Continuous	5 mm + 2 ppm	<0.15
Foil	5 mm + 2 ppm	2.4

Beam interruptions, severe heat shimmer and moving objects within the beam path can result in deviations of the specified accuracy.

Characteristics

Principle:	Phase measurement
Type:	Coaxial, visible red laser
Carrier wave:	658 nm
Measuring system:	System analyser basis 100 MHz - 150 MHz

14.3 Distancer, Measurements without Reflectors (Reflectorless mode)

Range

A2 (without reflector)

Kodak Gray Card	Range D		Range E		Range F	
	[m]	[ft]	[m]	[ft]	[m]	[ft]
White side, 90 % reflective	150	490	180	590	≤250	≤820
Grey side, 18 % reflective	80	260	100	330	≤110	≤360

A4 (without reflector)

Kodak Gray Card	Range D		Range E		Range F	
	[m]	[ft]	[m]	[ft]	[m]	[ft]
White side, 90 % reflective	200	660	300	990	>400	>1310
Grey side, 18 % reflective	100	330	150	490	>200	>660

A6 (without reflector)

Kodak Gray Card	Range D		Range E		Range F	
	[m]	[ft]	[m]	[ft]	[m]	[ft]
White side, 90 % reflective	350	1150	450	1480	≤600	≤1970
Grey side, 18 % reflective	200	660	250	820	≤350	≤1150

Range of Measurement: 1.5 m to 1200 m
 Display unambiguous: up to 1200 m

Atmospheric conditions

Range D: Object in strong sunlight, severe heat shimmer
 Range E: Object in share, or overcast
 Range F: Day, night and twilight

Accuracy

Standard measuring	ISO 17123-4	Measure time, typical [s]	Measure time, maximum [s]
0 m - 500 m	3 mm + 2 ppm	3 - 6	12
>500 m	4 mm + 2 ppm	3 - 6	12

Beam interruptions, severe heat shimmer and moving objects within the beam path can result in deviations of the specified accuracy.

Continuous measuring*	Standard deviation	Measure time, typical [s]
Continuous	5 mm + 3 ppm	0.25

* Accuracy and measure time depend on atmospheric conditions, target object and observation situation.

Characteristics

Type: Coaxial, visible red laser
 Carrier wave: 658 nm
 Measuring system: System analyser basis 100 MHz - 150 MHz

Laser dot size

Distance [m]	Laser dot size, approximately [mm]
at 30	7 x 10
at 50	8 x 20

14.4 Distance Measurement Reflector (Long Range)

Range

A2, A4, A6, (with reflector)	Range A		Range B		Range C	
	[m]	[ft]	[m]	[ft]	[m]	[ft]
Standard prism	2200	7300	7500	24600	>10000	>33000
Reflector foil 60 mm x 60 mm	600	2000	1000	3300	1300	4200

Range of measurement: From 1000 m up to 12000 m

Display unambiguous: Up to 12 km

Atmospheric conditions

Range A: Strong haze, visibility 5 km; or strong sunlight, severe heat shimmer

Range B: Light haze, visibility about 20 km; or moderate sunlight, slight heat shimmer

Range C: Overcast, no haze, visibility about 40 km; no heat shimmer

Accuracy

Standard measuring	ISO 17123-4	Measure time, typical [s]	Measure time, maximum [s]
Long range	5 mm + 2 ppm	2.5	12

Beam interruptions, severe heat shimmer and moving objects within the beam path can result in deviations of the specified accuracy.

Characteristics

Principle:	Phase measurement
Type:	Coaxial, visible red laser
Carrier wave:	658 nm
Measuring system:	System analyser basis 100 MHz - 150 MHz

14.5 Conformity to National Regulations

14.5.1 Zoom 20

Conformity to national regulations



Hereby, GeoMax AG, declares that the instrument is in compliance with the essential requirements and other relevant provisions of applicable European Directives. The declaration of conformity is available from GeoMax AG.

14.5.2 Zoom 30

Conformity to national regulations

- FCC Part 15 (applicable in US).
- Hereby, GeoMax AG, declares that the Zoom 30 instrument is in compliance with the essential requirements and other relevant provisions of Directive 1999/5/EC. The declaration of conformity is available from GeoMax AG.



Class 1 equipment according European Directive 1999/5/EC (R&TTE) can be placed on the market and be put into service without restrictions in any EEA Member state.

- The conformity for countries with other national regulations not covered by the FCC part 15 or European directive 1999/5/EC has to be approved prior to use and operation.
-

Frequency band

2402 - 2480 MHz

Output power

Bluetooth: 2.5 mW

14.6 General Technical Data of the Instrument

Telescope

Magnification:	30 x
Free Objective aperture:	40 mm
Focusing:	1.7 m/5.6 ft to infinity
Field of view:	1°30'/1.66 gon.
	2.7 m at 100 m

Compensation

Quadruple axis compensation (2-axis compensator with HA-collimation and VA-Index).

Angular accuracy	Setting accuracy		Setting range	
	["]	[mgon]	[']	[gon]
2	0.5	0.2	±4	0.07
3	1	0.3	±4	0.07
5	1.5	0.5	±4	0.07
7	2	0.7	±4	0.07

Level

Circular level sensitivity: 6'/2 mm
Electronic level resolution: 2"

Control unit

Display: 280 x 160 pixels, LCD, backlit, 8 lines with 31 characters each, heatable (temp. <-5°).

Instrument Ports

Name	Description
RS232	6 pin Hiroshi for power, communication, data transfer. This port is located at the base of the instrument.
USB host port*	USB memory stick port for data transfer.
Bluetooth*	Bluetooth connections for communication and data transfer.

* Only for Zoom 30 instruments.

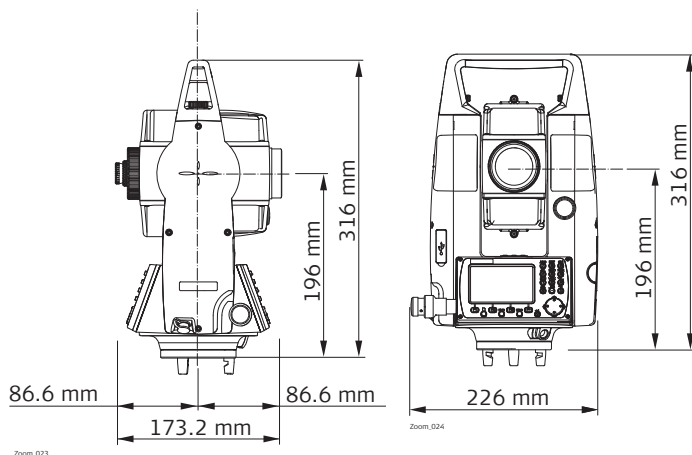
**Instrument
Dimensions**

Weight

Instrument:	4.2 kg - 4.5 kg (depending on hardware configuration)
Tribrach:	760 g
Battery ZBA400:	110 g

Tilting axis height

Without tribrach: 196 mm
With tribrach: 240 mm ±5 mm

Recording

Model	Memory Type	Number of measurements
Zoom 20 / Zoom 30	Internal memory	10,000

Laser plummet

Type: Visible red laser class 2
Location: In standing axis of instrument
Accuracy: Deviation from plumbline:
1.5 mm (2 sigma) at 1.5 m instrument height
Diameter of laser point: 2.5 mm at 1.5 m instrument height

Power

External supply voltage: Nominal voltage 12.8 V DC, Range 11.5 V-14 V
(via serial interface)

Battery ZBA400

Type:	Li-Ion
Voltage:	7.4 V
Capacity:	2.2 Ah
Operating time*:	approximately 9 hours

* Based on a single measurement every 30 s at 25°C. Operating time may be shorter if battery is not new.

Environmental specifications
Temperature

Type	Operating temperature		Storage temperature	
	[°C]	[°F]	[°C]	[°F]
Zoom instrument	-20 to +50	-4 to +122	-40 to +70	-40 to +158
Battery	-20 to +50	-4 to +122	-40 to +70	-40 to +158
USB memory stick	-40 to +85	-40 to +185	-50 to +95	-58 to +203

Protection against water, dust and sand

Type	Protection
Zoom instrument	IP54 (IEC 60529)

Humidity

Type	Protection
Zoom instrument	Max 95% non condensing. The effects of condensation are to be effectively counteracted by periodically drying out the instrument.

Automatic corrections

The following automatic corrections are made:

- Line of sight error
- Tilting axis error
- Earth curvature
- Standing axis tilt
- Vertical index error
- Refraction
- Compensator index error
- Circle eccentricity

14.7 Scale Correction

Use of scale correction

By entering a scale correction, reductions proportional to distance can be taken into account.

- Atmospheric correction.
 - Reduction to mean sea level.
 - Projection distortion.
-

Atmospheric correction

The distance displayed is correct if the scale correction in ppm, mm/km, which has been entered corresponds to the atmospheric conditions prevailing at the time of the measurement.

The atmospheric correction includes:

- Adjustments for air pressure
- Air temperature

For highest precision distance measurements, the atmospheric correction should be determined with:

- An accuracy of 1 ppm
 - Air temperature to 1°C
 - Air pressure to 3 mbar
-

Atmospheric corrections °C

Atmospheric corrections in ppm with temperature [°C], air pressure [mb] and height [m] at 60 % relative humidity.

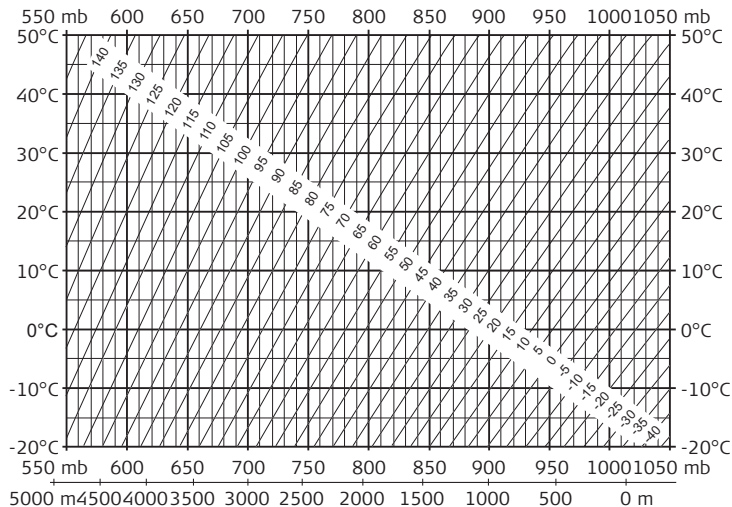

**Atmospheric
correction °F**

Atmospheric corrections in ppm with temperature [°F], air pressure [inch Hg] and height [ft] at 60 % relative humidity.

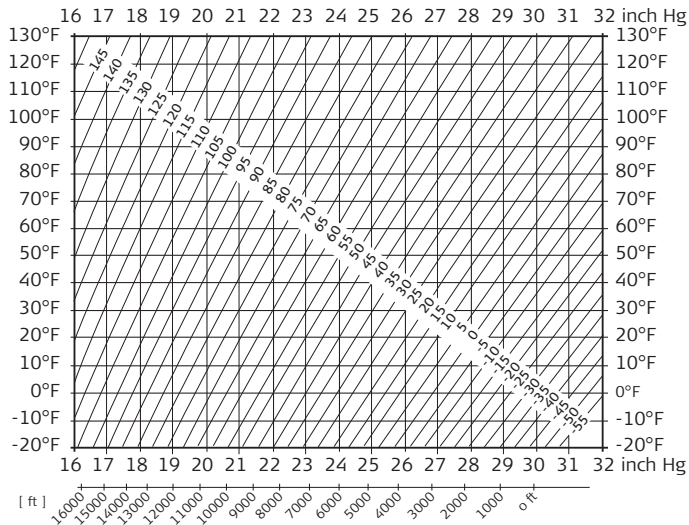

14.8 Reduction Formulas

Formulas

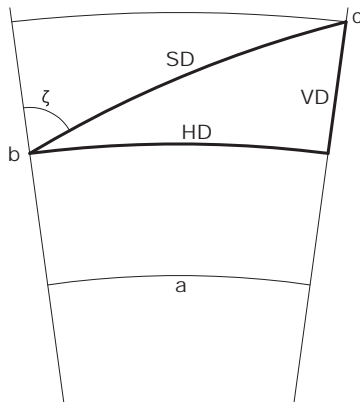

- a Mean Sea Level
- b Instrument
- c Reflector
- SD Slope distance
- HD Horizontal distance
- VD Height difference

The instrument calculates the slope distance, horizontal distance, and height difference in accordance with the following formulas. Earth curvature ($1/R$) and mean refraction coefficient ($k = 0.13$) are automatically taken into account when calculating the horizontal distance and height difference. The calculated horizontal distance relates to the station height and not to the reflector height.

Slope distance

$$SD = D_0 \cdot (1 + \text{ppm} \cdot 10^{-6}) + \text{mm}$$

SD Displayed slope distance [m]

D0 Uncorrected distance [m]

ppm Atmospheric scale correction [mm/km]

mm prism constant [mm]

Horizontal distance

$$HD = Y - A \cdot X \cdot Y$$

HD Horizontal distance [m]

Y SD * sin ζ

X SD * cos ζ

ζ = Vertical circle reading

A $(1 - k/2)/R = 1.47 \cdot 10^{-7}$ [m⁻¹]

k = 0.13 (mean refraction coefficient)

R = 6.378 * 10⁶ m (radius of the earth)

Height difference

$$VD = X + B \cdot Y^2$$

VD Height difference [m]

Y SD * sin ζ

X SD * cos ζ

ζ = Vertical circle reading

B (1 - k)/2R = 6.83 * 10⁻⁸ [m⁻¹]

k = 0.13 (mean refraction coefficient)

R = 6.378 * 10⁶ m (radius of the earth)

15 International Limited Warranty

International Limited Warranty

This product is subject to the terms and conditions set out in the International Limited Warranty which you can download from the GeoMax home page at <http://www.geomax-positioning.com/internationalwarranty> or collect from your GeoMax distributor. The foregoing warranty is exclusive and is in lieu of all other warranties, terms or conditions, express or implied, either in fact or by operation of law, statutory or otherwise, including warranties, terms or conditions of merchantability, fitness for a particular purpose, satisfactory quality and non-infringement, all which are expressly disclaimed.

Software Licence Agreement

This product contains software that is preinstalled on the product, or that is supplied to you on a data carrier medium, or that can be downloaded by you online according to prior authorisation from GeoMax. Such software is protected by copyright and other laws and its use is defined and regulated by the GeoMax Software Licence Agreement, which covers aspects such as, but not limited to, Scope of the Licence, Warranty, Intellectual Property Rights, Limitation of Liability, Exclusion of other Assurances, Governing Law and Place of Jurisdiction. Please make sure, that at any time you fully comply with the terms and conditions of the GeoMax Software Licence Agreement.

Such agreement is provided together with all products and can also be referred to and downloaded at the GeoMax home page at <http://www.geomax-positioning.com/swlicense> or collected from your GeoMax distributor.

You must not install or use the software unless you have read and accepted the terms and conditions of the GeoMax Software Licence Agreement. Installation or use of the software or any part thereof, is deemed to be an acceptance of all the terms and conditions of such Licence Agreement. If you do not agree to all or some of the terms of such Licence Agreement, you must not download, install or use the software and you must return the unused software together with its accompanying documentation and the purchase receipt to the distributor from whom you purchased the product within ten (10) days of purchase to obtain a full refund of the purchase price.

16 Glossary

Instrument axis

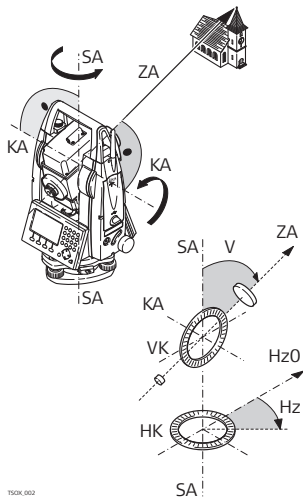

TS0K_002

- ZA = Line of sight / collimation axis**
Telescope axis = line from the cross hairs to the center of the objective.
- SA = Standing axis**
Vertical rotation axis of the telescope.
- KA = Tilting axis**
Horizontal rotation axis of the telescope. Also known as the Trunion axis.
- V = Vertical angle / zenith angle**
- VK = Vertical circle**
With coded circular division for reading the vertical angle.
- Hz = Horizontal direction**
- HK = Horizontal circle**
With coded circular division for reading the horizontal angle.

Plumb line / compensator



Direction of gravity. The compensator defines the plumb line within the instrument.

Standing axis inclination



Angle between plumb line and standing axis. Standing axis tilt is not an instrument error and is not eliminated by measuring in both faces. Any possible influence it may have on the horizontal direction or vertical angle is eliminated by the dual axis compensator.

Zenith

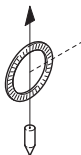

Point on the plumb line above the observer.

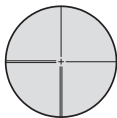
Crosshairs

Glass plate within the telescope with reticle.

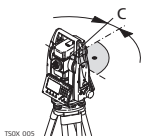
Line-of-sight error (horizontal collimation)

The line-of-sight error (c) is the deviation from the perpendicular between the tilting axis and line of sight. This could be eliminated by measuring in both faces.

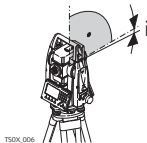
Vertical index error

With a horizontal line of sight the vertical circle reading should be exactly 90° (100 gon). The deviation from this value is termed the Vertical index error (i).

Explanation of displayed data

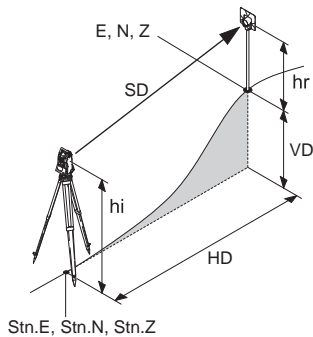

- SD Indicated meteorological corrected slope distance between instrument tilting axis and center of prism/laser dot
 - HD Indicated meteorological corrected horizontal distance
 - VD Height difference between station and target point
 - hr Reflector height above ground
 - hi Instrument height above ground
 - $Stn.E, Stn.N, Stn.Z$
Easting, Northing and Height coordinates of station
 - E, N, Z
Easting, Northing and Height coordinates of target point
-

Appendix A Menu Tree



Depending on local firmware versions the menu items may differ.

Menu Tree



Apps

- Survey
- Reference Element
- COGO
- Missing Line Measurement
- Resection
- Setout
- Area & Volume
- Remote Elevation
- Construction



Data

- Jobs
- Known Points
- Observations
- Code Library
- Formats
- Erase Job Memory
- Memory Info
- USB-Explorer



Settings



General

Contrast, Tilt Correction, HA Correction, Face I Definition, HA Increment, VA-Setting, Angle Unit, Minimum Reading, Distance Unit, Temperature Unit, Pressure Unit, Beep, Sector Beep, Screen Illumination, Crosshair Illumination, Heating, Data Output, GSI Format, Mask, Code Saving, Language, Auto-Off.



EDM

EDM Setting, Atmospheric Data, Free Entry PPM, Projection Scale, EDM Signal Reflection, EDM Frequency



Comm.

Communication Settings, Bluetooth Code



Survey



Transfer

Export Data
Import Data



Tools



Calibration

HA-Collimation

Vertical Index



Auto start



System Info

Instrument Information, Software Information, Set Date, SetTime



Load Firmware

Firmware, Languages Only

Appendix B Directory Structure

Description

On the USB memory stick, files are stored in certain directories. The following diagram is the default directory structure.

Directory Structure

—	CODES	<ul style="list-style-type: none">• Codelists (*.cls)
—	FORMATS	<ul style="list-style-type: none">• Format files (*.fmt)
—	JOBS	<ul style="list-style-type: none">• GSI, DXF, ASCII files (*.*)• Logfiles created from applications
—	SYSTEM	<ul style="list-style-type: none">• Firmware files• Language files• Configuration files (*.cfg)

Index

2		
2 Dist. Offset	78	
A		
Accuracy		
Angle measurement	222	
IR mode	224	
Reflectorless mode	226	
RL mode	229	
Angle measurement	222	
Angle unit, setting of	51, 72	
Application		
Survey	102	
Applications		
Area & Volume	151	
COGO	126	
Construction	157	
Reference Element	104, 116	
Remote Elevation	155	
Resection	138	
Set Out	146	
Applications - Getting Started	87	
Pre-settings for applications	88	
Select Job	90	
Select Orientation	94	
Select Station	92	
Set accuracy limit	139	
Set EDM	157	
Area & Volume, application	151	
Atmospheric data, setting of	59	
Auto start routine	65	
Auto-Off, setting of	55	
B		
Base line	105	
Battery		
Changing of	37	
Charging	36	
First-time use	36	
Icon	22	
Labelling	221	
Technical data ZBA400	236	
Baudrate	62	

Beep, setting of	53	Cleaning and Drying	191
Bluetooth		Code	
Code	61	Bluetooth Code	61, 173
Communication setup	62	Code Library	84
Connection	173	Coding	
Data transfer	174	Code library	71
Icon	23	Data management	163
Output power	231	Editing / Extending	86
Safety directions	217	GSI coding	84
C		COGO, application	126
Calibration	176	Collimation axis	246
Combined calibration	179	Communication Settings	61
Electronic	176, 181	Compensation	232
Errors, view current	64	Compensator, icon	22
Inspecting laser plummet	186	Connecting Bluetooth	173
Line of sight	179	Constants, prism	59
Mechanical	177	Construction, application	157
Of circular level on instrument	184	Container contents	15
Of circular level on tribrach	184	Continuous, EDM	83
Preparation	178	Contrast, setting of	47
Vertical index	179	Control Distance	81
Care	189	Coordinates, orientation with	97
Circular level, calibration of	184		

Corrections

Atmospheric	238
Automatic	237
Scale	238
Crosshair illumination, setting of	54
Crosshairs	248

D

Data

Storage	39
Transfer	165
Data formats	169
Data management	162, 162
Data output, setting location of	54
Data types	169
Databits	62
Date	67
Delete last observation	71
Dimensions, of instrument	234
Directory structure	253
Display heater, setting of	54
Display, technical details of	233
Distance Offset	73
Distance unit, setting of	52, 72

E

Edit fields, how to	26
Electromagnetic compatibility EMC	216
Electronic calibration	176
Electronic Distance Measurement EDM	44
RL Mode	208, 225
Settings	57
Continuous	83
Icons	22
Laserbeam	59
Prism (Long Range)	228
Prism constant	59
Prism mode	223
Prism Types	58
Signal reflection	60
Electronic level, level up instrument	33
Endmark	63
Erase job memory	163
Export data	165
Extension, COGO application	134

F

Face, setting of	49
FCC Statement	219
Fields, common	101

File extensions	169
Firmware information	68
Folder structure	253
Formats, management of	163
Formatting	
Internal memory	68
Free PPM, setting of	60
Functions FNC	
Access	71
Description of	71
FNC key	19

G

GGO/GGO Tools	
Description	14
Glossary	246
GSI	
Coding	84
Output mask, setting of	55
Output format, setting of	55

H

HA corrections, setting of	48
HA increment	49
Horizontal angle, setting of	49

I

Icons	22
Import data	169
Instrument	
Components	17
Dimensions	234
Level up	33
Ports	233
Settings	47
Setup	30
Technical Data	232
Instrument components	17
Instrument information	67
Intended Use	194
International Limited Warranty	244
Intersections, COGO application	129
Inverse and traverse, COGO application	127

J

Job, management of	162
--------------------------	-----

K

Keyboard	19
Keys	19
Known point data	163

L

Labelling	207, 211, 214, 220, 221
Language	
Deleting	47
Upload language	69
Language, setting of	55
Laser	
Classification	205
Distancer	44
Laser plummet	
Adjust intensity	35
Inspect	186
Safety directions	213
Technical data	235
Laserbeam	
On/Off	71
Setting of	59
Level	233
Level / Plummet screen, access	71
Li-Ion battery	
Storage	190
Limits of use	196
Line of sight	248
Calibration	179

M

Main menu	40
Manual angle setting, orientation	95
Manual, validity of	4
Mechanical calibration	177
Memory information, management of	163
Menu tree	250
Minimum reading, setting of	51

N

Navigation key	20
----------------------	----

O

Observation data	163
Offsets, COGO application	132
Operating concept	13
Operating temperature	236
Operation, of instrument	30
Orientation	
Manual angle setting	95
With Coordinates	97

P		
Parity	63	
Plumb line	247	
Point search	28	
Pole Length	79	
Ports		
Communication setup	61	
Instrument ports	233	
PPM, setting of	60	
Pressure unit, setting of	52	
Prism		
GeoMax constant	59	
Type	58	
Prism measurements	45	
Projection scale, setting of	60	
Q		
Quadruple-axis compensation	232	
R		
Recording code, setting of	55	
Reduction Formulas	241	
Reference Arc, application	116	
Reference Line, application	104	
Refraction coefficient	242, 243	
		Remote Elevation, application
		155
		Remote point
		156
		Resection, application
		138
		Responsibilities
		197
		RL measurements
		44
		RL/IR Change
		71
		RS232, communication setup
		62
		S
		Safety Directions
		193
		Screen
		21
		Screen illumination, setting of
		53
		Search
		28
		Sector beep, setting of
		53
		Select job
		90
		Select orientation
		94
		Select station
		92
		Set Out, application
		146
		Settings, configuration of
		47
		Settings, setting of
		47
		Setup
		Instrument
		30
		Tripod
		30
		Softkeys
		24

Software		Load Software	69
Loading	69	System Information	67
Software information		Transport	189
Application information	68	Tripod	
Standing axis	247	Service	188
Stopbits	63	Setup	30
Storage	190	U	
Storage temperature	236	Units, settings of	51
Survey application	42, 102	Upload languages	69
T		Upload software	69
Technical data	222	USB	
Telescope	232	Directory Structure	253
Temperature		Explorer	164
Battery	236	Icon	23
Instrument	236	Inserting	172
USB stick	236	User Interface	19
Temperature unit, setting of	52	V	
Terminology	246	Vertical angle	
Tilt and horizontal corrections	56	Description	246
Tilt correction, setting of	47	Setting of	50
Time	67	Vertical index	
Tools		Calibration	179
Auto start	65	Description	248
Calibration	64		

W

Weight	234
Wildcard search	29

Z

Z-Coordinate	72, 76
Zenith	50, 247
Zenith angle	246
Zoom 30 frequency band	231

GeoMax Zoom 20 / Zoom 30 Series



780085-1.0.0en

Original text

© 2010 GeoMax AG, Widnau, Switzerland